

FableKids

love inspired.



3 IN 1 Travel System

"MILA"



Thank you for choosing **FableKids**.

Please read the instructions carefully before use and keep for future reference.

FableKids

love inspired.

Dear Parents,
Thank you for purchasing our product. Please read the operating instructions carefully before using the product for the first time. If you give the product to a third party, this manual must be handed over with it. Keep the instruction manual for future reference. The drawings in this manual may not match the physical objects. Please refer to the physical objects.

"MILA" 3 in 1 Travel System Available Configurations



Car Seat



Carry cot



Stroller / pushchair

FableKids

love inspired.

Table of Contents

1. Important Safety Information -----	1
2. Product Overview -----	3
3. Assembly and Set Up -----	5
4. Carrycot Set Up -----	8
5. Seat Unit Set Up -----	10
6. Carrycot/Stroller Attachment -----	12
7. Car Seat Installation -----	14
8. How To Use The Stroller -----	15
9. Accessories -----	18
10. Maintenance and Care -----	19
11. Environmentally friendly disposal -----	20





love inspired.

1. Important Safety Information



WARNING

IMPORTANT: Read these instructions carefully before use and keep them for future reference. Your child's safety may be affected if you do not follow these instructions. Failure to follow these warnings and the instructions could result in serious injury or death.

- Never leave your child unattended.
- Do not use if any part is broken, torn or missing.
- This product is not suitable for running or skating.
- Do not take your stroller on the escalator.
- Avoid using stairs when the child is in the pram/stroller.
- Care should be adopted when moving the pram/stroller up and down curbs and steps.
- When adjusting the product components, children should be kept clear of moving parts while making adjustments.
- Always apply the brake when loading or unloading your child.
- Always apply the brake whenever the pram/stroller is stationary.
- To avoid danger of suffocation to babies and children keep plastic bags out of their reach.
- Ensure that all the locking devices are engaged before use.
- To avoid injury, ensure that your child is kept away when unfolding and folding this product.
- Always use the restraint system in combination with the seat unit.
- Check that the pram body or seat unit or car seat attachment devices are correctly engaged before use.
- Only use the seat units, carrycots, car seats, accessories and approved replacement parts approved by original manufacturer.
- Do not make any changes to this product.
- Your child should be clear of moving parts before adjusting the position of the backrest, foot rest or canopy.
- Ensure that your baby is comfortable and does not overheat when using the rain cover. The mesh ventilation panels on the sides of the rain cover are essential to aid the flow of cool air around your baby. The top section should be opened or the rain cover removed unless it is raining or very cold.
- Never use force. Adjustments and locks should be free and easy to operate.
- Do not use near an open fire or exposed flame.
- The carrycot and seat unit of this product is manufactured for use with the MILA pram chassis.
- We recommend using this product with the FableKids car seats.
- For car seat used in conjunction with a chassis, this vehicle does not replace a cot or a bed. Should your child need to sleep, then it should be placed in a suitable pram body, cot or bed.

Strangulation hazard:

- A child can strangle in loose restraint straps. Never leave your child in the carrier when straps are loose or undone.
- Strings can cause strangulation! Do not place items with a string around a child's neck, such as hood strings or pacifier cords. Do not suspend strings over a carrycot or cradle or attach strings to toys.



love inspired.

1. Important Safety Information

Recommended weights:

- This vehicle is intended for children from birth up to 22kg or 4 years whichever comes first.
- Age and weight usage: Carrycot 0 to 9kg, Car seat 0 to 13kg (follow manufacturers guidelines), Seat unit (used as a single stroller) 6 months to 22kg or 4 years whichever comes first
- Each seat unit carrycot or car seat is suitable for one child only to the maximum weight stated above. Maximum occupancy for this vehicle is one child.
- The product will become unstable if the manufacturers recommended load is exceeded.
- Any load attached to the handlebar affects the stability of the pram/stroller.
- The maximum weight for the shopping basket is 2.5kgs.

Using the carrycot on the chassis:

- The carrycot is only suitable for a child who cannot sit up unaided, roll over and cannot push itself up on its hands and knees. Maximum weight of the child 9kg.
- The carrycot is not intended for use by children older than 6 months or children who can sit unaided.
- Do not use a mattress pad other than the one provided by original manufacturer.
- Only use on a firm, horizontal level and dry surface.
- Do not place the carrycot near an open fire or other source of strong heat.

Using the seat unit on the chassis:

- Always use the harness to avoid injury from falling or sliding out.
- Always use the crotch strap in combination with the waist belt.
- The seat is not suitable for children under 6 months unless they can sit unaided.
- The harness should be correctly adjusted to provide a snug fit around your child. Adjust using the buckles on the shoulder, waist and crotch straps.

Using the carrycot or seat unit independently of the chassis:

- Never use the carrycot on a stand.
- This carrycot is not intended to use on its own as a sleeping unit. It is manufactured to use with the chassis of the stroller.
- Do not let other children play unattended near the carrycot or seat.
- The seat unit is only to be used with the chassis of this system MILA.
- Never use the carrycot on an elevated surface.
- Never use the carrycot/seat unit as a means for transporting your child in a motor vehicle.
- The handles and the bottom of the carry cot should be inspected regularly for signs of damage and wear.
- Before carrying or lifting, make sure that the handle(s) is (are) in the correct position of use.
- The head of the child in the carry cot should never be lower than the body of the child.

2. Product Overview



- | | | | |
|----------------------------|-----------------------------|-------------------------|-----------------------|
| A. Handlebar Cover | I. Storage Basket | R. Seat/Carrycot Frame* | AB. Car seat adaptors |
| B. Handlebar Adjuster | J. Rear Wheel | S. Carrycot Fabric | AC. Car seat hood |
| C. Right Folding Button | K. Wheel Disassembly Button | T. Seat Unit Fabric | AD. Car seat |
| D. Left Folding Button | L. Canopy | U. Chassis | AE. Bag |
| E. Seat Unit | M. Bumper Bar | V. Carrycot Apron | AF. Changing mat |
| F. Seat Disassembly Button | N. Canopy Connector | W. Foot Warmer | |
| G. Joint Point Cover | O. Recline Buttons | X. Seat Liner | |
| H. Brake Bar | P. Revolving Lock | Y. Rain cover | |
| | Q. Front Wheel | Z. Mosquito Net | |

* **Note: The Carrycot/Seat Unit Frame (R) and the Carrycot Fabric (S) are already assembled.** When converting from carrycot mode to stroller mode, the carrycot fabric will need to be removed from the carrycot frame in order for the seat unit to be assembled with component (T).

FableKids

love inspired.

2. Product Overview



FableKids

love inspired.

3. Assembly and Set Up

Step 1: Unfolding the Stroller



a. Squeeze the stroller frame together slightly whilst pulling the release catch as shown.



b. Pull the stroller upwards until you hear the frame click into the upright position. Test the chassis by pushing downwards on the handle bar to make sure it is securely locked in to place at the joint.



3. Assembly and Set Up

Step 2: Brake Bar Installation



a. Please ensure the chassis is unfolded before installing the brake bar and wheels. Attach the brake bar to the rear of the chassis as shown above.

b. Ensure the silver locking clips are visible on each side and test this by pulling the brake bar downwards once it has been installed.

Step 3: Rear Wheel Installation



a. To attach the rear wheels simply press the center button whilst pushing on to each side of the axle. Test this by trying to remove the wheels without pressing the center button.

To disassemble the wheels push the center button and pull.

3. Assembly and Set Up

Step 4: Front Wheel Installation

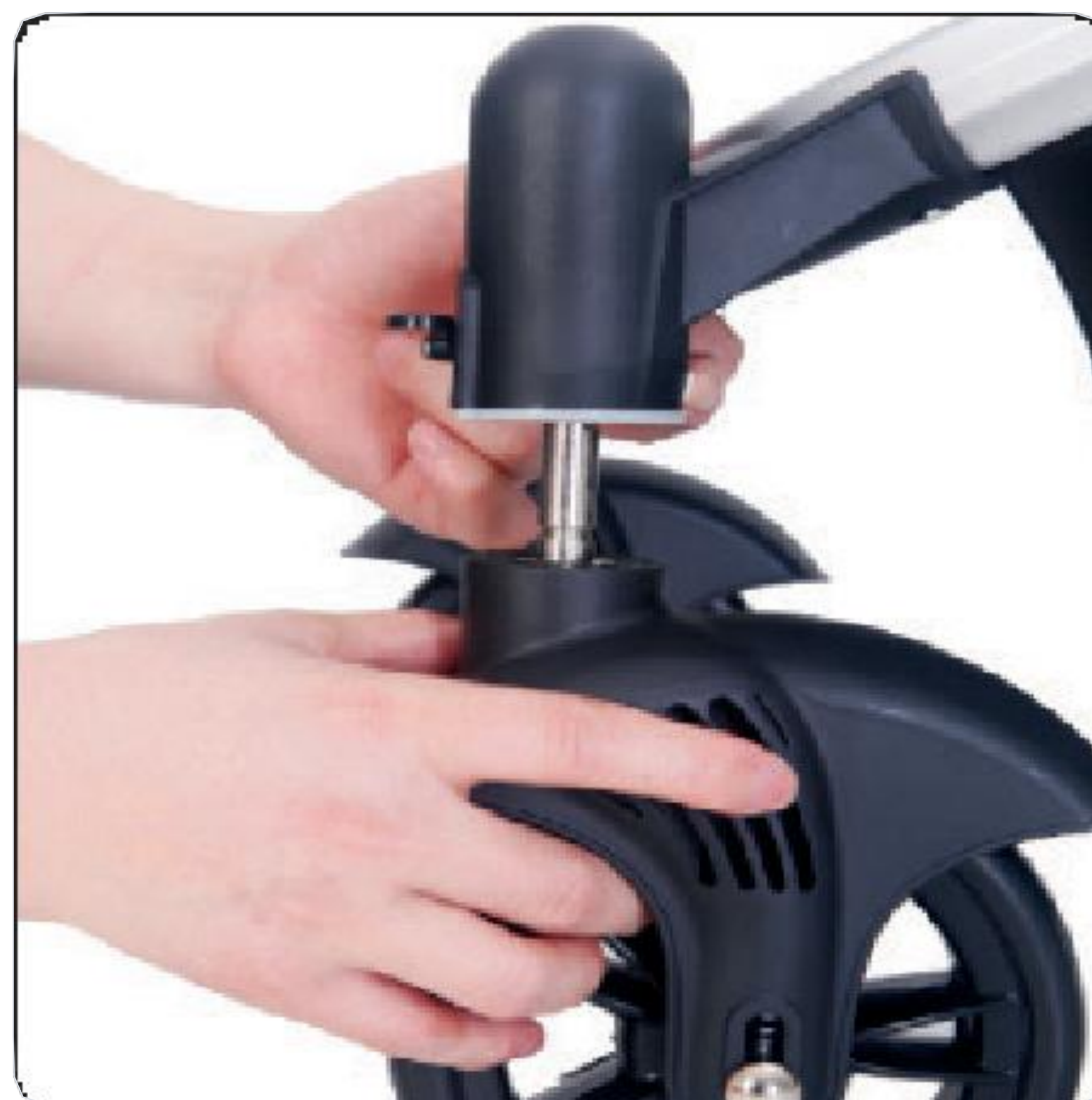

a. Keep holding the front wheel button and attach the front wheel onto the chassis. Repeat other side.

b. Please ensure you test your installation by pulling the front wheel down a few times before using



NOTE: Please ensure that the front wheels are locked when using on rough terrain.

4. Carrycot Set Up

Step 1: Preparing the Carrycot



a. The carrycot fabric should already be attached to the carrycot/seat unit frame.

PLEASE NOTE: The position of the carrycot may need to be adjusted to make it level. This can be done by firmly pressing on the recline buttons located either side of the carrycot frame, as shown above.

Step 2: Bumper Bar Installation



a. Line up the holes on each side before pushing firmly into place.



b. To remove, press the center button inwards whilst pulling the bumper bar upwards.



love inspired.

4. Carrycot Set Up

Step 3: Canopy Installation



- a. clip the connector on both sides of the canopy onto the frame tube. Assembly finished.



- b. Adjust the canopy by pulling the fabric to desired size.

- c. Unzip the zipper to use the ventilation layer.

5. Seat Unit Set Up

Step 1: Preparing the Seat Unit



a. Remove the carry cot fabric from the frame in preparation for the seat unit attachment



b. To attach the seat unit, first slide the top of the seat fabric onto the top of the chassis.



c. Feed the two narrow fabric trim panels positioned either side of the seat unit, into the slots on the inside of the seat frame which are positioned just below the bumper bar attachment point in the middle of the seat frame



d. Attach the seat unit fabric using the velcro strips and eyelet hooks. Ensure the recline button is at the top of the seat unit and accessible.



e. Clip the canopy onto the frame and zip onto the seat unit fabric.

PLEASE NOTE:

The seat unit is suitable for children 6 months or over.



love inspired.

5. Seat Unit Set Up

Step 2: Seat Harness Attachment

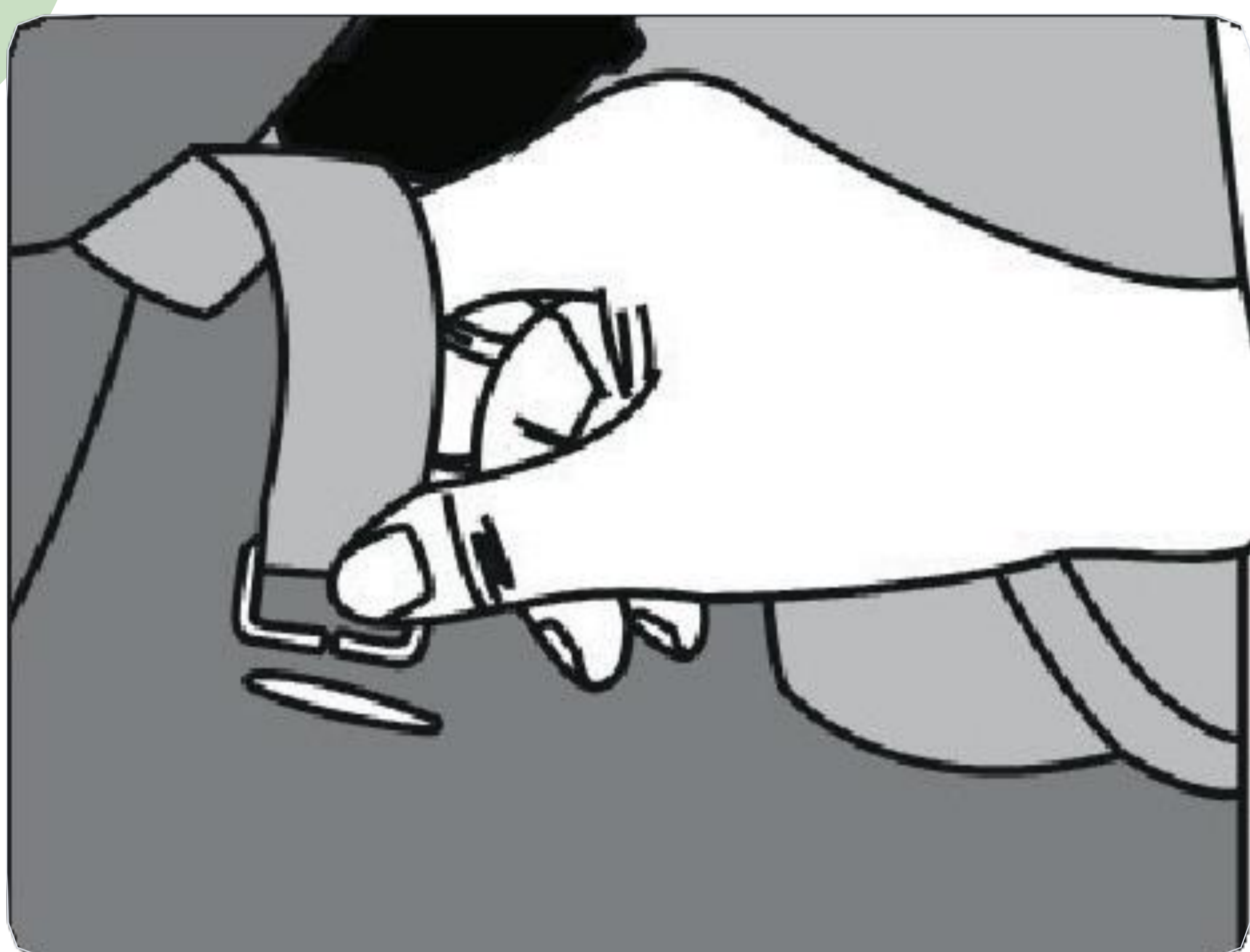

a. Locate the holes which can be found on either side of the seat section of the seat unit fabric.

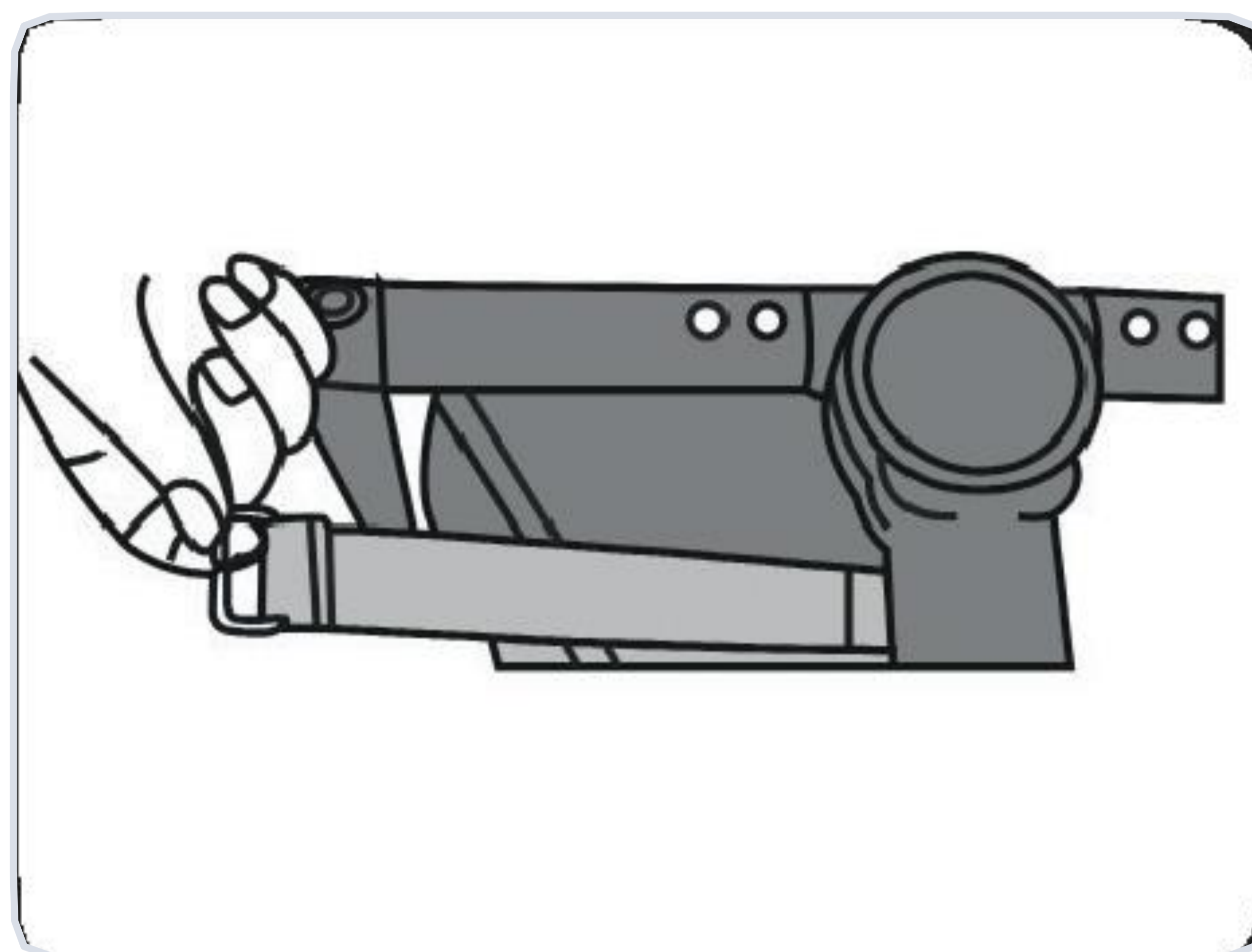

b. Slide the waist strap through the holes with the silver buckle end going from inside to out.

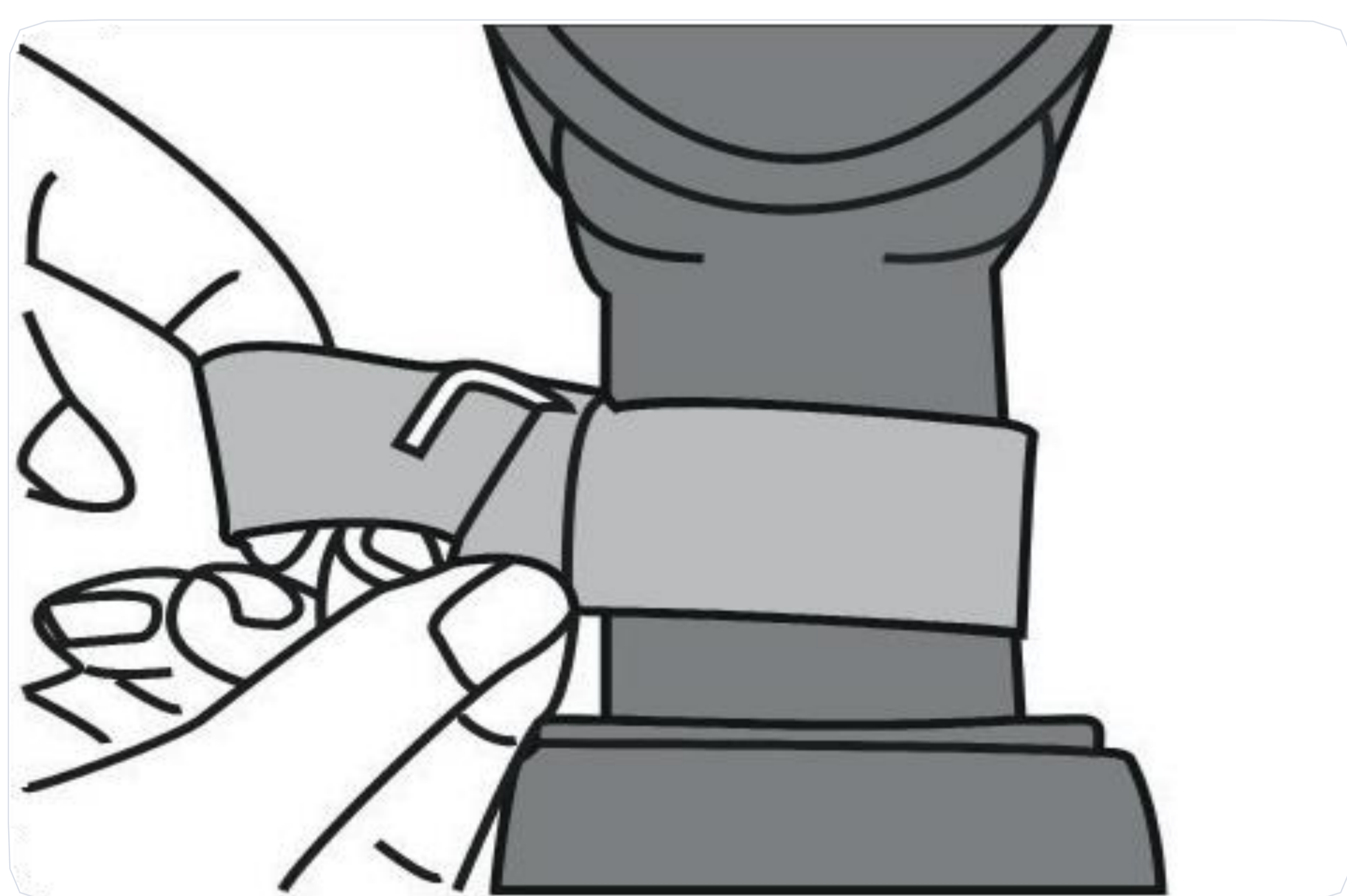

c. Loop the strap around the circular piece of the chassis located just above the release clips and then slide the material through the small gap between the silver buckle.

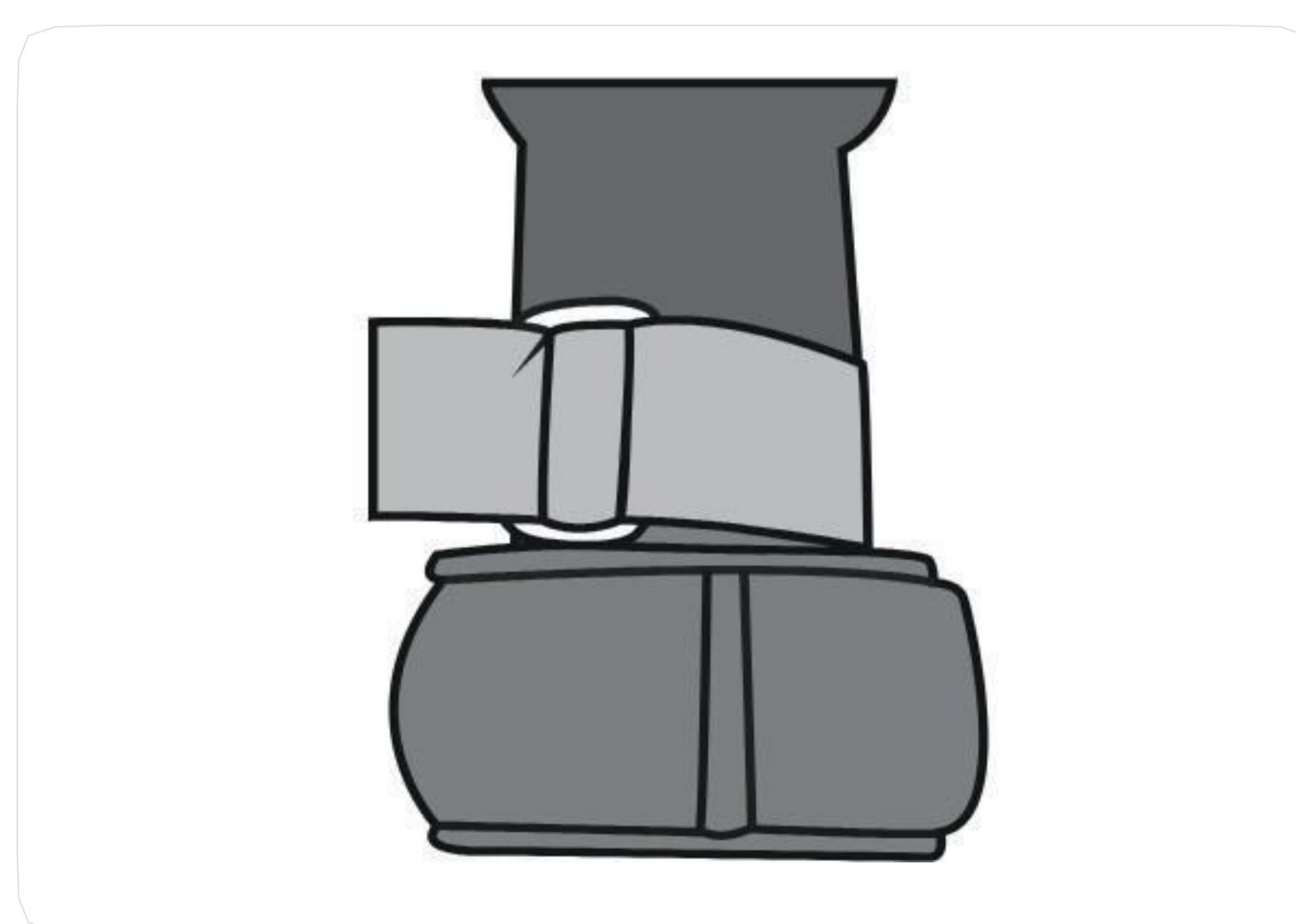

d. Complete. Adjust length of the harness to desired position, ensuring a snug fit.

6. Carrycot/Stroller Attachment

Installation



a. Line up the release clips with the chassis and then push down until both sides click into place. Please test this by pulling upwards.

Please note: There may be a slight movement to the carrycot when it is locked onto the chassis.

Disassembly



b. Push the release buttons forward until you feel it click before lifting upwards to remove.

7. Car Seat Installation

Step 1: Adapter Attachment



a. IMPORTANT: Insert the adapters into the car seat before attaching to the chassis, and keep them engaged to the car seat.

Step 2: Car Seat Hood Attachment



b. Locate the hood along the car seat and press the two side buttons together to secure in position.

7. Car Seat Installation

Step 3: Car Seat Attachment

a. Line up the adapters with each side of the chassis before pushing down on each side. Please be aware that even pressure will need to be placed on both sides at the same time when pushing downwards.



Step 4: Car Seat Removal



b. Locate the hood along the car seat and press the two side buttons together to secure in position.



b. Engage and hold each clip while lifting the car seat upwards.

Please note: This is a different technique to the Carrycot/Stroller removal

8. How To Use The Stroller

Front Wheel Lock Feature



To lock the front wheels in place, simply press the button downwards. Pull upwards to release and enable 360 degree turn



IMPORTANT: Ensure the wheels are in a locked position when using on uneven or rough terrain.

Handlebar Adjustment



To adjust the height of the handlebar press the buttons on each side inwards simultaneously whilst lifting up or down.

Seat Reclining Adjustment

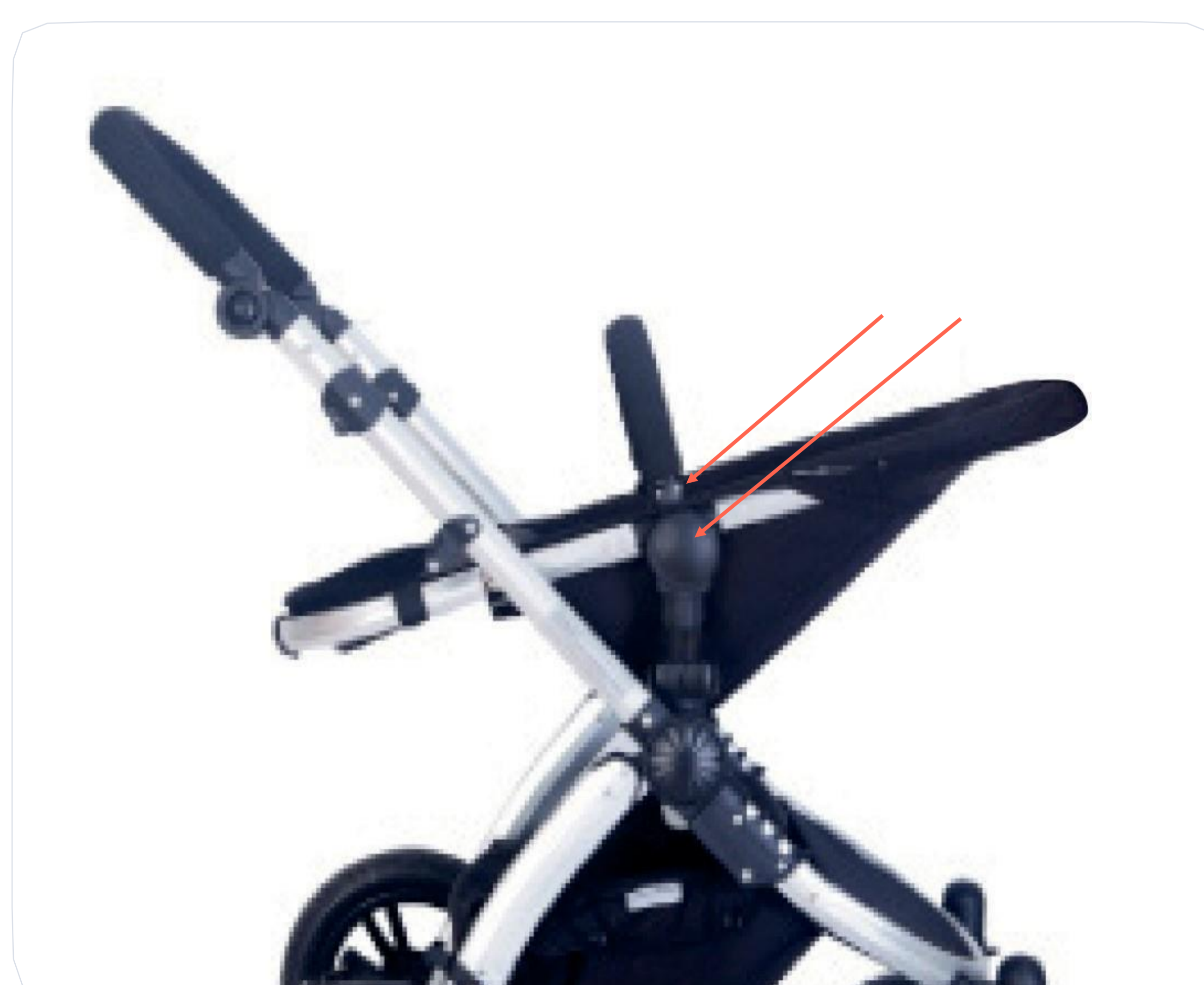

To adjust the recline of the stroller, press the two recline buttons inwards simultaneously. There are 4 recline positions.

8. How To Use The Stroller

Reversing the Seat Unit



To reverse the seat unit direction, simply follow the same steps as indicated in chapter 6.

Travel System Brake



To apply the brake simply push down. To remove the brake function lift upwards.

Safety Harness



Insert A onto B. Put A, B and C together and click into place.
Repeat on the opposite side.

Harness Release



Press button D to release.

8. How To Use The Stroller

Folding The Stroller



Press and hold down the fold button with your index finger.



Whilst holding down the fold button, pull both levers towards you and then fold the chassis down..



Follow the arrow direction.



Secure the chassis in place using the folding lock.

9. Accessories

Raincover / Mosquito net



Line up the seams on the rain cover / mosquito net with the seams on the hood. Open the window of raincover using the velcro to ensure sufficient ventilation..

Carrycot Apron



Secure the carrycot apron in place by fastening the poppers on each side.

Seat Liner



Thread the harness of the seat unit through the slots of the seat liner to secure it into place - only when in stroller mode.

Foot warmer



Attach the bottom part of the foot warmer to the underside of the seat unit frame. Then, wrap the top part of the foot warmer under and over the bumper bar and secure in place using the poppers.



love inspired.

10. Maintenance and care

- Apply a damp cloth to plastic parts of the stroller. Avoid abrasives or bleach.
- Regularly check screws, rivets, bolts and fastenings to ensure they are locked tight and secure. Replace any parts in an inferior condition. When using this product during the winter, by the sea or off-road it is important to clean using clean fresh water and dry thoroughly. Salt water and salt and grit from the roads will corrode metal parts unless removed.
- Check on a regular basis that all chassis locking devices are working correctly.
- Do not expose the product to excessive sunlight for extended periods of time, even normal exposure to sunlight may cause change to the color of the fabrics.
- Take care not to tear fabrics when transporting the product.
- Light oil or silicone spray can be used to lubricate moving parts.
- Ensure zips are either fully open or closed to prevent damage.
- Do not place items on top of the hood/canopy, it could damage the fabrics or render the product unsafe.
- Do not use a buggy board with this product as it will invalidate your warranty.
- The safety harness should be checked on a regular basis to ensure that the webbing has not become frayed or damaged.

Fabric care:

- All stroller fabrics are rainproof. If stroller becomes wet, do not fold the hood when you take it inside. Keep away from strong heat sources such as fires, radiators and direct sunlight. Always allow the fabric to dry naturally.
- Even though fabrics are carefully selected and tested; washing wearing and normal exposure to sunlight may cause some color change.
- Remember when storing or transporting your stroller and accessories that exposed edges of fabric cover are often the first to wear and fray.

Washing Instructions:

- Machine Washable Fabrics - Carrycot Apron, Foot Warmer, and Seat Liner. These items can be washed in a washing machine on a cool wash setting.
- Handwash Only Fabrics - Canopy Fabrics (carry cot/stroller and car seat hood). Sponge clean only using a mild detergent and warm water (30°).
- Do not use abrasives or bleach.

11. Environmentally friendly disposal

Warning Danger of suffocation! Packaging material is dangerous for children. Never let children play with packaging material.

11.1 Disposal and packaging

The packaging of your unit consists of materials that are necessary to guarantee effective protection during transport. These materials are fully recyclable and therefore reduce the environmental impact. Dispose of the packaging in a bin for recyclable materials.

11.2 Disposal of old equipment

Old appliances must be disposed of in accordance with the guidelines and regulations of the local waste disposal authority. Check with your local administration for the address of the nearest recycling center and deliver your appliance there.



The symbol of the crossed-out dustbin on a Waste electrical or electronic equipment indicates that it must not be disposed of with household waste at the end of its life. Collection points for waste electrical and electronic equipment are available free of charge in your area. You can obtain the addresses from your city or local government. You can find out about other return options created by us on our website

www.fable-kids.com

The separate collection of Waste electrical or electronic equipment is intended to enable the reuse, recycling or other forms of recovery of Waste electrical or electronic equipment and to avoid the negative consequences of disposal on the environment and human health.



FableKids

love inspired.



Office address:
Fablekids
Gneisenaustraße 10-11
D-97074 Würzburg

Return address can be found in the imprint: <https://www.fable-kids.com>

VAT identification number: DE 263752326
Court of the Commercial Register is Würzburg, HRB 10082
WEEE Reg.-No. DE 61617071



Office address: FableKids • Gneisenaustraße 10-11 •
97074 Würzburg



Our customer service number:
Tel. +44 (0) 208 068 5604



E-Mail: info@fable-kids.co.uk



Return address can be found in the imprint: <https://www.fable-kids.com>