

AREBOS

Engine stand

AR-HE-MS550



Please follow all security measures in this user's manual to ensure a secure use.



Thank you for trusting in AREBOS.

List of contents

1. Safety instructions	3
2. Description and parts list	4
3. Assembly	5
4. Technical specifications.....	5
5. Disposal instruction	6
5.1 Disposal of the packaging.....	6
5.2 Disposal of waste equipment.....	6

Please read and save these instructions. Read through this user's manual carefully before using product. Protect yourself and others by observing all safety information, warnings and cautions. Failure to comply with instructions could result in personal injury and/or damage to product or property. Please retain instructions for future reference.

1. Safety instructions

Explanation of the symbols



By means of a CE marking, it can be recognized that a product complies with the legal requirements of European legal standards and therefore may be traded within the European Community.



Warning! Heavy duty!

- **Warning!** Ensure all Health and Safety, local authority, and general workshop practice regulations are strictly adhered to when using this equipment.
- Before using the stand ensure it is in good working order.
- Replace or repair damaged parts. Use recommended parts only. Unauthorized parts may be dangerous and will invalidate the warranty.
- Keep the stand clean for best and safest performance.
- Locate the stand in a suitable work area, keep area clean and tidy and free from unrelated materials. Ensure there is adequate lighting.
- Use on a firm, level surface capable of sustaining the stand and the load.
- Maintain correct balance and footing. Ensure the floor is not slippery and wear non-slip shoes.
- Ensure all non-essential persons keep a safe distance whilst the stand is in use.
- Lock mounting plate in position with locking pin before fixing a load and ensure the load is centered and securely mounted on the mounting plate.
- When an engine is mounted, take the weight of the engine on the handle **before** removing the locking pin.
- Ensure the stand and load is stable.
- To move a loaded stand, steady the load and push from behind the main post of the stand so that the castor wheels are ahead of the load.
- **DO NOT** pull the unit backwards, or push from the side, as this may cause the stand to tip.
- Ensure surface over which the stand is to travel is strong enough to take the stand and load and that it is not cracked, uneven or obstructed.
- **DO NOT** use unit if damaged.
- **DO NOT** allow untrained persons to use the stand.
- **DO NOT** exceed the rated capacity of 550 kg.
- **Danger!** **DO NOT** work under an engine mounted on the stand.
- **DO NOT** use the stand for purposes other than those for which it is designed.
- When not in use, store in a safe, dry, childproof location.

2. Description and parts list

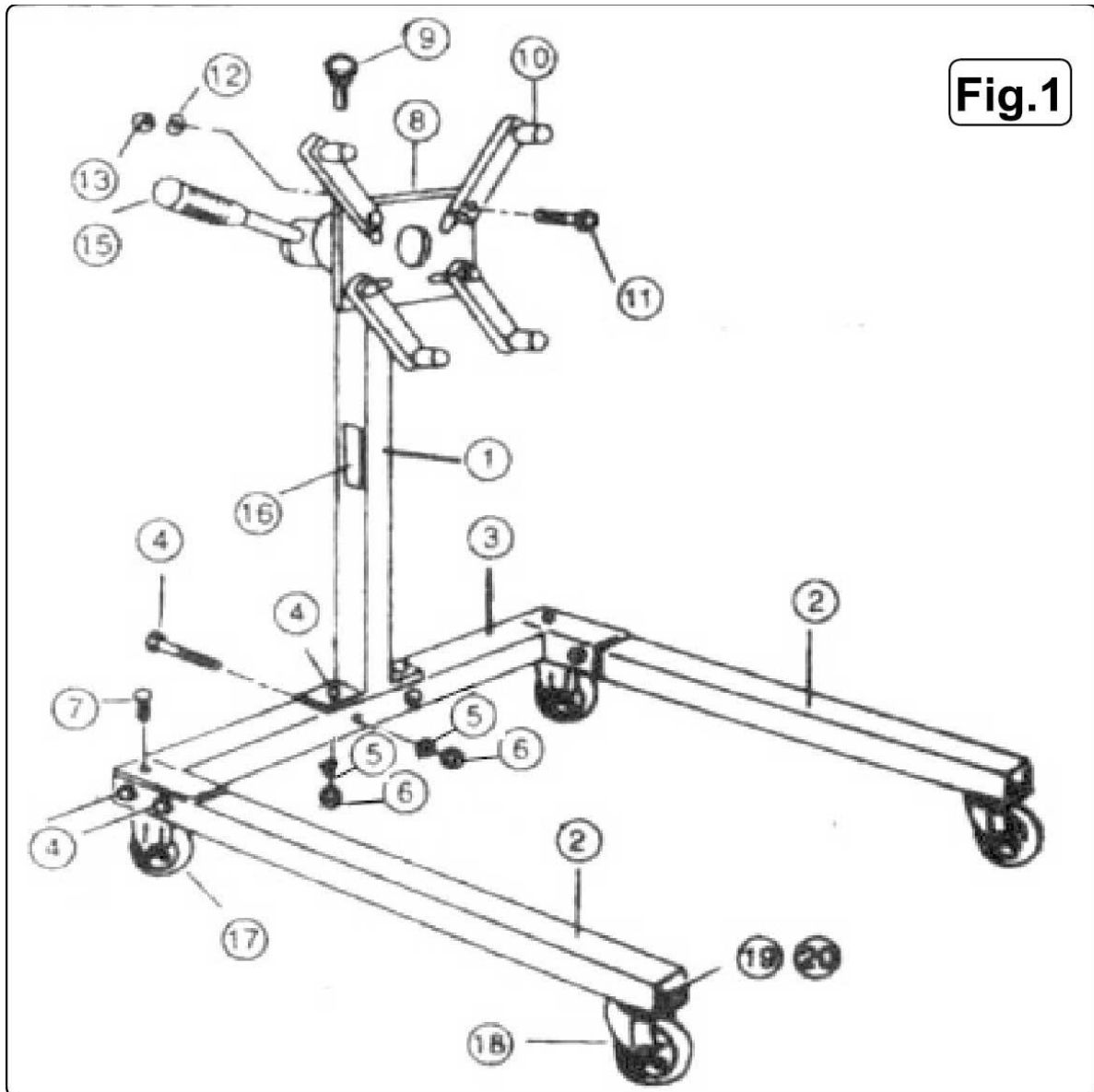

Parts list

Part	Parts Number	Name
1	V3-01	Main Post
2	V3-02	Front leg
3	V3-03	Main Post Support
4	V3-04	Bolt (0,5" x 3,5")
5	V3-05	Locking Washer (0,5")
6	V3-06	Hex Nut (0,5") NC
7	V3-07	Bolt (0,5" x 1")
8	V3-08	Head Mounting Plate
9	V3-09	Locking Pin
10	V3-10	Mounting Arm
11	V3-11	Bolt (0,5" x 2,5")
12	V3-12	Flat Washer (0,5")
13	V3-13	Hex Nut (0,5")
14	V3-14	Rotation Handle
15	V3-15	Main Post Label
16	V3-16	Rear Wheel (3,5")
17	V3-17	Castel Wheel, Front
18	V3-18	Bolt (5/16" x 5/8")
19	V3-19	Hex Nut (5/16") NC

3. Assembly

Note: The following numbers refer to Fig.1 and the parts list below.

- Remove head mounting plate (8) from main post (1).
- Loosely attach main post (1) to main post support (3) with bolts (4), washers (5) and nuts (6).
- Attach front legs (2) into main post support (3) and loosely secure with bolt (7&4), washers (5) and nuts (6).
- Fit front castors (18) to castor legs (2) with nuts (20) and bolts (19).
- Refit head mounting plate (8) to main post (1) and locate with locking pin (9).
- Attach the four mounting arms (10) to head mounting plate (8) with bolts (11), washers (12) and nuts (13).
- Insert handle (15) through hole in stem of mounting plate (8).
- Apply weight evenly across the main post support (3) and front legs (2), making sure that all four castor wheels are on level ground and the frame is sitting square and true, then tighten all nuts and bolts. Remove weight and check that the unit is sitting correctly with all four castors in contact with the ground.

4. Technical specifications

Model	AR-HE-MS550
Max. Capacity	1212 lbs (550 kg)
Width	34.65 in (880 mm)
Length	38.19 in (970 mm)
Height	36.02 in (915 mm)

5. Disposal instruction

5.1 Disposal of the packaging

- Please make reference to the guidelines and standards for appropriate disposal of the packaging valid in your region. In part, the package may consist of plastic bags - watch this respect, with special care to ensure that this is not out of the reach of children. There is a risk of suffocation!

5.2 Disposal of waste equipment

- Equipment must be disposed of in accordance with the rules and regulations of the local waste disposal.
- At the end of the long life of your article, please dispose of the valuable raw materials for proper disposal so that proper recycling can take place. If you are not sure how to proceed, the local waste disposal companies or recycling centers are happy to help.

Our customer service number: +49 (0) 931-45232700

EU Declaration of Conformity

We,

Canbolat Vertriebs GmbH, Gneisenaustraße 10-11, 97074 Würzburg, Germany,

Hereby declare that the product named below, seen its design and construction as well as according to our sales, has been complied with the relevant and basic health and safety EU-requirements.

Name of the product: AREBOS Engine Stand
Art. Nr.: 4260199757017
Model Nr.: AR-HE-MS550

If the product has any modification not allowed by us, this declaration loses its validity.

EU Standard:
EN ISO 12100:2010
Related to CE Directive:
2006/42/EC

Date/Manufacturer Signature/Location:

Würzburg, 18.03.2019



Identification of the signatory:
Korhan Canbolat, head of the company

Authorised representative for the technical documentation:
Korhan Canbolat

Office address:
Canbolat Vertriebs GmbH
Gneisenaustraße 10-11
D-97074 Würzburg

Return address can be found in the imprint: <https://www.arebos.de/impressum/>

VAT identification number: DE 263752326
Court of the Commercial Register is Würzburg, HRB 10082
WEEE Reg.-No. DE 61617071