

List of contents

1. Safety instructions	3
1.1 Icon description.....	3
1.2 General safety instructions.....	4
1.3 Safety instructions for working with compressed air and blow guns.....	5
1.4 Safety instructions for paint spraying.....	6
1.5 Safety instructions for the compressor.....	6
1.6 Operation of pressure vessels	8
1.7 Check compressor and delivery.....	8
2. Parts list and delivery.....	8
3. Intended use.....	11
4. Exploded view.....	12
5. Technical specifications.....	14
6. Assembly and operation	15
7. Cleaning and maintenace	19
7.1 General.....	19
7.2 Clean the compressor.....	20
7.3 Drain condensation	20
7.4 Check compressor	20
7.5 Exchange mains connection cable	21
7.6 Carbon brushes	21
7.7 Safety valve	21
7.8 Maintenance	21
7.9 Transportation	21
7.10 Storage.....	21
8. Troubleshooting	22
9. Disposal instruction	23
9.1 Disposal of the packaging	23
9.2 Disposal of waste equipment	23
9.3 Meaning of the "dustbin"	23

Please read and save these instructions. Read through this user's manual carefully before using product. Protect yourself and others by observing all safety information, warnings and cautions. Failure to comply with instructions could result in personal injury and/or damage to product or property. Please retain instructions for future reference.

1. Safety instructions

1.1 Icon description



Declaration of conformity: Products marked with this symbol comply with all applicable Community legislation of the European Economic Area.



Warning! Read the safety instructions carefully. The Failure to follow the safety precautions could result in serious injury or damage. Keep the operating instructions in a safe place.



Wear ear protection.



Warning of electrical voltage.



Warning of hot parts. The surfaces of the compressor may heat up during operation.



Warning: compressor can start without warning.



Prohibition: Do not switch on the compressor before the compressed air hose is connected.



The compressor must always stand straight.

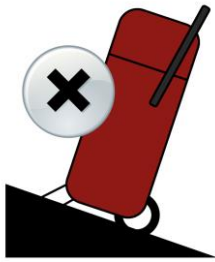

The compressor must not be placed on an incline.



The guaranteed sound power level is 97 dB(A).

1.2 General safety instructions

- Keep your work area in order.
 - Clutter in the work area can result in accidents.
- Consider environmental influences.
 - Do not expose the compressor to rain.
 - Do not use the compressor in humid or wet environments.
 - Ensure good lighting of the work area. Do not use the compressor where there is a risk of fire or explosion, i. e. not near flammable liquids or gases.
- Protect yourself from electric shock.
 - Avoid body contact with grounded parts (e.g. pipes, radiators, electric stoves, refrigerators).
- Keep other people away.
 - Do not let other people, especially children, touch the compressor or the power cord. Keep them away from your work area.
- Store your compressor safely.
 - The unused compressor should be parked in a dry and locked room, out of the reach of children.
- Do not overload your compressor.
 - You work better and safer in the specified performance range.

- Wear suitable work clothes.
 - Do not wear loose clothing or jewelry, they could be caught by moving parts.
 - When working outdoors, sturdy shoes are recommended.
 - Wear a hairnet for long hair.
- Use protective equipment.
 - Wear safety glasses.
 - Use a breathing mask when working on dust.

- Do not misuse the cable or the hose!
 - Do not use the power cord to unplug the power cord from the wall outlet. Protect the cable from heat, oil and sharp edges.
- Maintain your compressor with care.
 - Keep your compressor clean to work well and safely.
 - Follow the maintenance instructions.
 - Regularly check the mains connection cable and the mains plug of the compressor and have them replaced by a recognized specialist if damaged.
 - Check extension cords regularly and replace them if they are damaged.
 - Keep handles dry, clean and free of oil and grease.
- Unplug the power plug.
 - When not using the compressor, before servicing and when changing tools.
- Avoid unintentional startup.
 - Make sure that the ON/OFF switch is set to "0" when the power plug is plugged into the socket.
- Use extension cords for outdoor use.
 - Only use approved extension cords outdoors and marked accordingly.
- Always be attentive.
 - Pay attention to what you do. Get to work with reason.
 - Do not use the compressor when you are unfocused, tired or under the influence of drugs, alcohol or medication.
- Check the compressor for any damage.
 - Before further use of the compressor, protective devices or slightly damaged parts must be carefully inspected for proper and intended function.
 - Check that the moving parts are working properly and are not jammed or that parts are damaged. All parts must be properly installed and meet conditions to ensure proper operation of the compressor.
 - Damaged safety devices and parts must be properly repaired or replaced by a recognized specialist workshop, unless otherwise stated in the operating instructions.
 - Damaged switches must be replaced by a qualified specialist.
 - Do not use compressors where the ON/OFF switch cannot be turned on and off.
- **Danger!** For your own safety, only use accessories specified in the operating instructions or recommended or specified by the manufacturer. The use of other tools or accessories other than those specified in the operating instructions may result in injury to you.
- **Attention!** Repairs only by a specialist.
 - This compressor complies with the relevant safety regulations.
 - Repairs may only be carried out by a qualified electrician using original spare parts; otherwise accidents can occur to the user.
- Noise emission protection.
 - Wear ear protection while using the compressor.
- Replacing the power cord.
 - If the power cord is damaged, it must be replaced by a qualified professional to avoid hazards.

- Installation site
 - Only install the compressor on a flat surface.

1.3 Safety instructions for working with compressed air and blow guns

- **Risk of injury!** The compressed air jet that you can create with the compressor has a high pressure. Incorrect handling of the compressor or the compressed air jet may result in injury.
 - Do not point the air jet or compressed air tools connected to the compressor towards

persons or animals.

- Do not use the compressed air jet to clean clothing on the body.
- Do not insert hands or objects through the protective grid of the compressor.
- Keep children and animals away from the working area of the compressor.
- When loosening the hose coupling, hold the coupling piece with your hand to avoid injury from the recoiling air hose.
- Make sure that all hoses and pressure tools are suitable for the maximum allowable working pressure of the compressor.
- At a working pressure of more than 7 bar, we recommend attaching the compressed air hoses to a safety cable (e.g. wire rope).
- Wear safety goggles and breathing mask when working with the compressor for protection against foreign bodies and blown parts.
- Check the compressor for rust and damage before each use. The compressor must not be operated with a damaged or rusty pressure vessel/compressed air tank. If you discover damage or rust, contact a qualified professional.
- **Danger of burning!** Compressors and lines reach high temperatures during operation. Touching leads to burns.
 - Do not touch the compressor and lines during operation to avoid burns.
 - Be careful when working.
- The gases or vapors sucked in by the compressor must be kept free from any admixtures that could cause fires or explosions in the compressor.
- Wear safety glasses and respiratory protection when working with the blow gun. Foreign objects, blown-off parts, and swirled-up dust can easily cause personal injury and damage to health through inhalation. Dust-raising work should be carried out outdoors.
- Warning: All hoses and fittings of road-going compressors must be suitable for use on construction sites at the maximum permissible pressure.
- Avoid heavy loads on the piping system by using flexible hose connections to prevent kinking.

1.4 Safety instructions for paint spraying

- Do not use paints or solvents with a flash point of less than 55 ° C.
- Do not heat paints and solvents.
- If harmful liquids are processed, filter devices (face masks) are required for protection. Also note the information provided by the manufacturers of such substances about protective measures.
- The information and markings of the Hazardous Substances Ordinance applied to the outer packaging of the processed materials must be observed. If necessary, additional protective measures must be taken, in particular appropriate clothing and masks to wear.
- Do not smoke during the spraying process or in the working area. Also paint vapors are easily combustible.
- Fireplaces, open light or sparking machines must not be present or operated.
- Do not store or consume food and drinks in the work area. Paint fumes are harmful.
- The working space must be greater than 30 m³ and sufficient air exchange must be ensured during spraying and drying. Do not splash against the wind. Always observe the regulations of the local police authority when spraying combustible or dangerous injection-molded parts.
- Do not use media such as white spirit, butyl alcohol and methylene chloride in connection with the PVC pressure hose (reduced service life).

1.5 Safety instructions for the compressor

- **Danger!** For your own safety, operate the compressor only after reading the safety instructions.
- **Risk of explosion!** If you operate the compressor in an unsuitable, poorly ventilated place, in

an unsuitable ambient temperature, or in a room containing dusts, acids, vapors, or flammable gases, there is a risk of explosion.

- The compressor must not be operated or stored in a room containing dusts, acids, vapors or flammable gases. He can explode.
- Keep away easily flammable substances from the compressor.
- Keep the gases or vapors sucked in from the compressor free of any impurities that could cause fires and explosions in the compressor.
- Operate the compressor only at an ambient temperature of at least 5°C and at a maximum of 40°C. At temperatures below 5°C, the motor startup is endangered by stiffness.
- Ensure that the ambient temperature in a closed working environment is not higher than 25°C to ensure proper operation of the compressor while maintaining full air charge.
- Only operate the compressor in well-ventilated areas.
- Do not spray water or flammable liquids on the compressor.
- **Risk of injury!** The compressor's compressed air tank is under pressure during operation and in the non-vented state. If the compressor is damaged, connections are loosened or unsuitable or damaged lines are used, pressure may be released.
 - The compressor must not be operated if the compressed air tank has defects that endanger the operator or third parties.
 - Check the compressed air tank for rust and damage before each use. If damage is found, contact a qualified specialist immediately.
 - Do not switch on the compressor before the compressed air hose is connected.
 - Never drill holes in the compressed air tank, do not weld or deform it.
 - Never operate the compressor if the compressed air tank is damaged or deformed.
 - Ensure that the compressed air tank is always vented before releasing connections or connecting or removing pneumatic tools.
 - Make sure that you only use compressed air lines for compressed air that are suitable for a maximum pressure that matches the device.
 - Use a compressed air hose with hose protection when working with a pressure of 7 bar or more.
 - Do not try to repair damaged wires, but replace them.
 - Never transport the compressor when the compressed air tank is pressurized.
- **Risk of electric shock!** Faulty electrical installation or excessive mains voltage can lead to electric shocks.
 - Only connect the compressor if the mains voltage of the socket agrees with the specification on the type plate.
 - Only connect the compressor to an easily accessible socket so that you can quickly disconnect it from the power supply in the event of a malfunction.
 - Lay the power cord so that it does not become a trip hazard.
 - Do not kink the power cord and do not put it over sharp edges.
 - Always disconnect the power plug from the wall outlet when not in use, before transporting and before cleaning or maintenance.
 - Do not use the compressor if the power cord or plug is damaged. Have the damaged part replaced by an authorized dealer for an original part.
- **Risk of damage!** Improper handling of the compressor can damage the compressor.
 - Do not insert any objects into the compressor.
 - Only transport the compressor by the transport handle provided for this purpose.
 - Always keep the compressor upright.
 - When the compressor starts up (starts), a brief voltage dip may occur, especially if the power quality is poor. This can affect other devices (e.g. flickering a lamp).

1.6 Operation of pressure vessels

- Anyone who operates a pressure vessel shall maintain it in a proper condition, operate it properly, monitor it, carry out any necessary maintenance and repair work immediately and take the necessary safety measures according to the circumstances.
- The supervisory authority may order necessary monitoring measures in individual cases.
- A pressure vessel may not be operated if it has defects that endanger employees or third parties.
- Check the pressure vessel for rust and damage before each use. The compressor must not be operated with a damaged or rusty pressure vessel. If damage is found, please contact a qualified specialist.

1.7 Check compressor and delivery

- Check the device and accessories for completeness and transport damage.
- If possible, keep the packaging until the end of the warranty period.
- **Swallowing and suffocation!** Children are not allowed to play with plastic bags, foils and small parts. Children can swallow small parts or put plastic bags and slides over their heads and choke on them.
 - Keep away children from the compressor, small parts and packaging material.
 - The compressor is not a toy.
- **Risk of injury!** The compressor is very heavy. If you lift it out of the packaging by yourself, you may injure yourself.
 - Do not lift the compressor out of the package alone, but with the help of another person.

2. Parts list and delivery



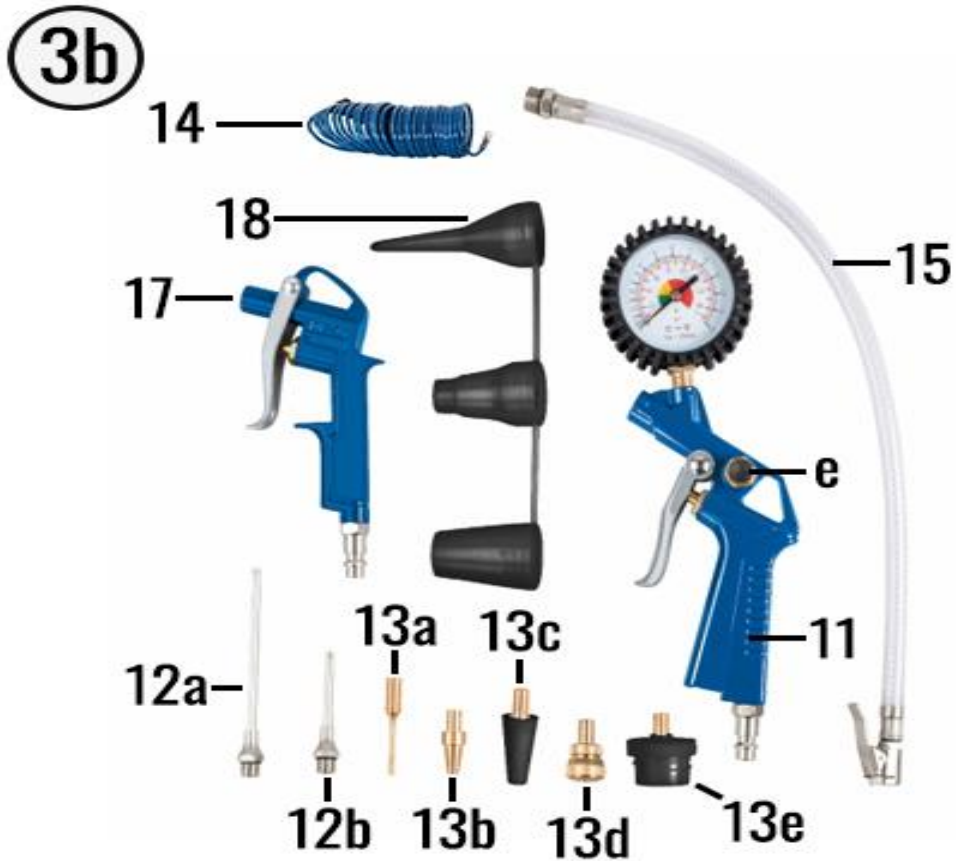
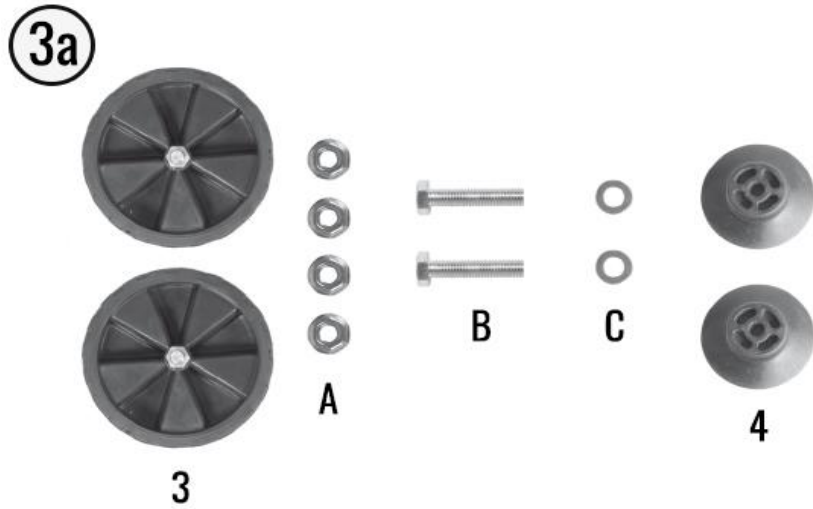
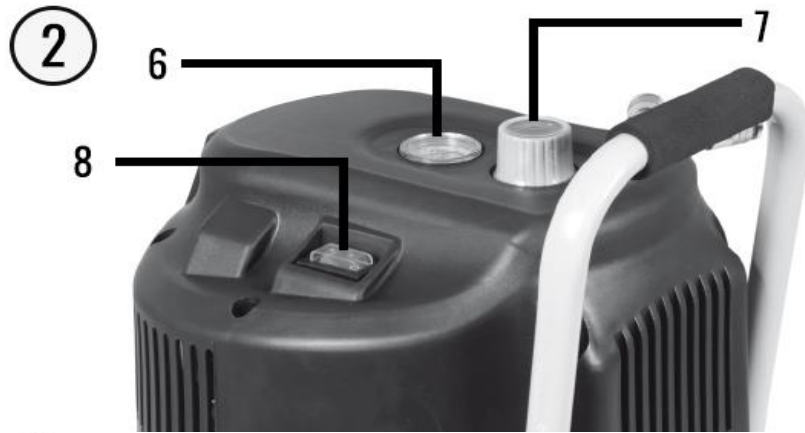

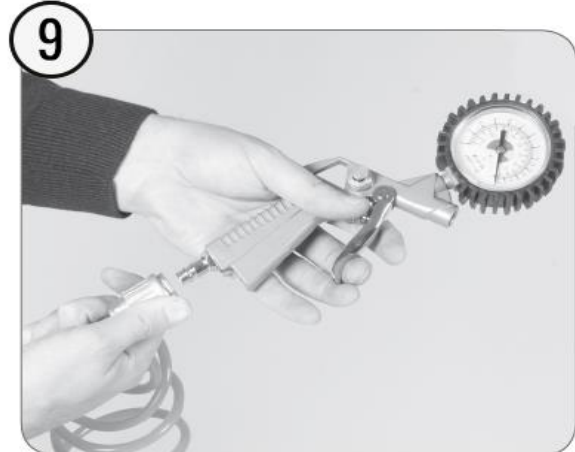
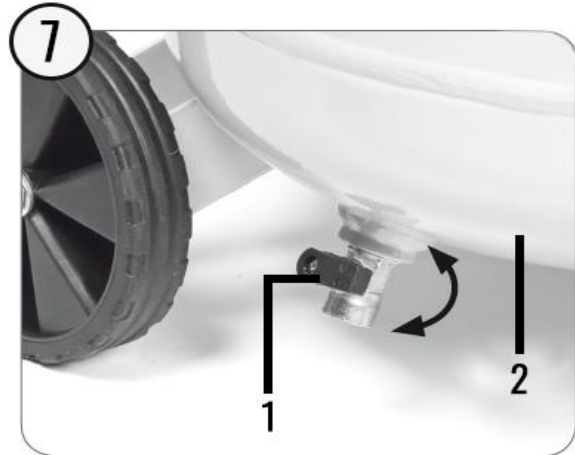
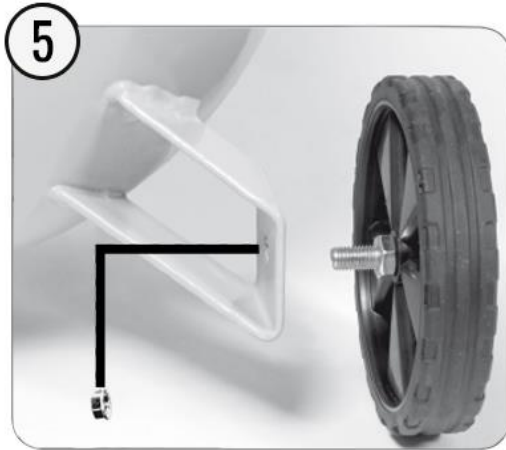
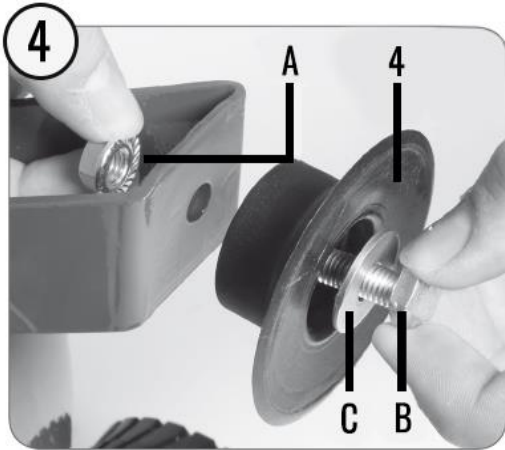

1. Drain valve for condensation water
2. Pressure tank
3. Wheel with axle bolt
4. Stand
5. Quick coupling (regulated compressed air) with Y connection
6. Pressure gauge (set pressure can be read)
7. Pressure regulator
8. ON/OFF switch
9. Transport handle
10. Holder for accessories
11. Tire inflator with pressure gauge

12. Blower adapter 2 parts (12a/12b)
 13. Adapter set 5 parts (13a-13e)
 14. Wire helix hose
 15. Filling hose (adapter for car valves)
 16. Safety valve
 17. Blow-out pistole
 18. Nozzles 3 parts
- A Locknut
B Screw
C Washer

Delivery

- 1x compressor
- 2x wheel with axle bolt
- 4x locknut
- 2x screw
- 2x washer
- 2x stand
- 1x tire inflation gauge with pressure gauge and filling hose
- 1x blow-out pistole
- 1x blow-out adapter (2-piece)
- 1x adapter set (5-piece)
- 1x spiral hose
- 1x quick coupling with Y connection
- 1x operation manual

3. Intended use

- The compressor is used to generate compressed air for compressed air tools.
- The device may only be used as intended. Any further use beyond this is not intended. The user/operator and not the manufacturer is liable for any damage or injury of any kind.
- Please note that our devices have not been designed for commercial, technical or industrial use as intended. We do not assume any warranty if the device is used in commercial, craft or industrial companies as well as in activities requiring equal treatment.

4. Exploded view

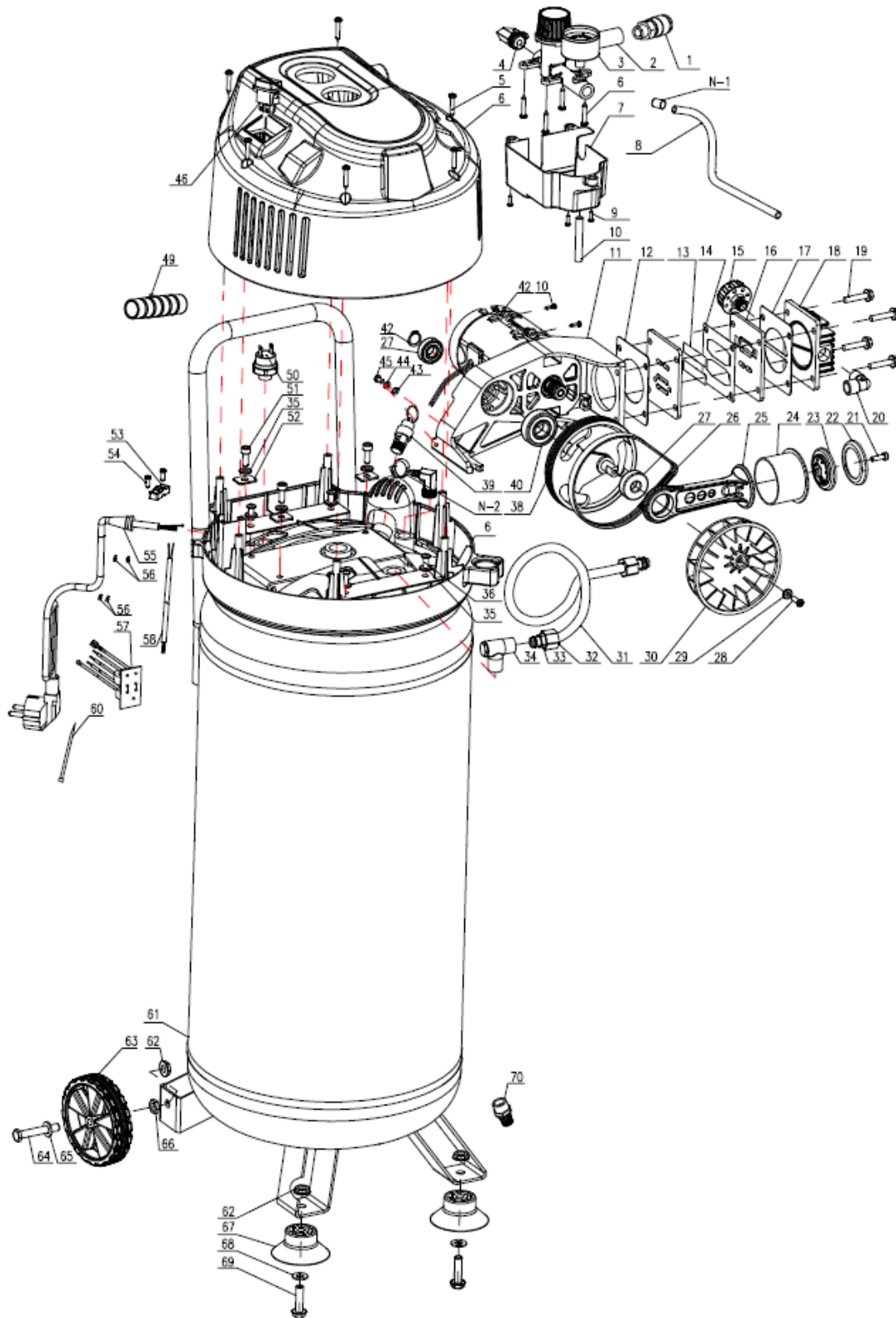

Number	Description	Qty	Number	Description	Qty
1	Quick coupling with Y connection	1	36	Screw	4
2	Pressure Regulator	1	38	Crankshaft	1
3	Pressure Gauge	1	39	Bearing	1
4	Elbow	1	40	Safety Valve	1
5	Screw	10	41	Motor Cover	1 Set
6	Cover	1 Set	42	Circlip	1
7	Cover guard	1	43	Washer	1
8	Hose	1	44	Washer	1
9	Screw	1	45	Screw	1
10	Hose	7	46	Power Switch	1
11	Motor	1	49	Handle rubber cover	1
12	Valve Plate Gasket	1	50	Pressure Switch	1
13	Valve	2	51	Screw	3
14	Aluminum Gasket	1	52	Cushion	3
15	Valve Plate	2	53	Plastic tablet	1
16	Air Filter	1	54	Screw	2
17	Cylinder Head Gasket	1	55	Plug	1
18	Cylinder Head	1	56	Terminal	4
19	Bolt	4	57	Circuit board	1
20	Elbow	1	58	Wire	1
21	Screw	1	60	Zip Tie	1
22	Piston Ring	1	61	Tank	1
23	Connection Rod Cover	1	62	Nut	4
24	Cylinder	1	63	Wheel	2
25	Connecting Rod	1	64	Bolt	2
26	Belt	1	65	Plain Washer	2
27	Bearing	2	66	Nut	2
28	Screw	1	67	Foot Pad	2
29	Plain Washer	1	68	Plain Washer	2
30	Fan	1	69	Bolt	2
31	Aluminum Pipe	1	70	Drain Cock	1
32	Nut	2	N-1	Ring	1
33	Plain Washer	2	N-2	Clamp	1
34	Check Valve	1			
35	Plain Washer	7			

5. Technical specifications

Model	AR-HE-LK150050S
Compressor	
Power	1500 W
Volume	50 L
Voltage	230 Va.c.
Frequency	50 Hz
Idle speed	4000 rpm
Theo. suction capacity	ca. 220 L/min
Protection type	IP20
Operating mode	S3 25%
Overheating protection	Max. 145 centigrade
Sound power level	97 dB(A)
Uncertainty K	1.61 dB(A)
Operating temperatur	+5° – 40°C
Weight	52.5 lbs (23.8 kg)
Pressure Switch (50)	
Switch-on pressure	Appr. 8 bar
Switch-off pressure	Appr. 10 bar
Wire helix hose (14)	
Length	500 mm
Material	Plastic (PE)
Inner/outer diameter	6/8 mm
Quick coupler	1/4"
Max. working pressure	8 bar
Max. pressure	24 bar
Blow-out pistole (17)	
Dimensions (length x width x height)	115 x 135 x 21 mm
Material	Steel
Coupling	1/4"
Working pressure	0-6 bar
Nozzel outlet diameter	7,7 mm
Nozzel outlet diameter (inner/outer) x length	5/3 x 160 mm
Nozzel outlet diameter (inner/outer) x length	5/3 x 80 mm
Inflating gun (11+15)	
Dimensions (length x width x height)	580 x 220 x 35 mm
Display range	0 - 12
Legth hose	360 mm
Material hose	PVC
Coupling	Quick coupling
Working pressure	0 - 6 bar
Blower adapter (12 a)	
Material	Steel
Thread (external)	M10x1; Length: 94 mm
Blower adapter (12 b)	
Material	Steel
Thread(external)	M10x1; Length: 50.5 mm

Adapter (13 a)	
Material	Cooper
Thread (external)	5/16"; Length: 45 mm
Adapter (13 b)	
Material	Cooper
Thread (external)	Ø7.8; Length: 30 mm
Adapter (13 c)	
Material	Rubber
Thread (external)	Ø7.8; Length: 44.5 mm
Adapter (13 d)	
Material	Rubber
Thread (external)	Ø7.8; Length: 28 mm
Adapter (13 e)	
Material	Cooper
Thread (external)	Ø7.8; Length: 27.5 mm
Adapters (18)	
Material	Plastic
Thread (external) 1: Length x Ø	50 x 32 mm
Thread (external) 2: Length x Ø	52 x 32 mm
Thread (external) 3: Length x Ø	90 x 32 mm

6. Assembly and operation

Notes on installation

- Remove transport material and any transport securing devices.
- Check device and accessories for completeness and integrity.
- Check the device for transport damage. Immediately report any damage to the carrier with which the compressor was delivered.
- Before commissioning, always assemble the device completely!
- Mount the compressor, if possible, with the help of another person.
- Before mounting, make sure you have enough space to install the compressor.
- Operate the device only on a firm level surface.
- The installation of the compressor should be close to the consumer.
- Long air lines and long supply lines (extension cables) should be avoided.
- Pay attention to dry and dust-free intake air.
- Do not install the compressor in humid or wet room.
- The compressor may only be operated in suitable rooms (well ventilated, ambient temperature +5 to 40°C). There must be no dust, acids, vapors, explosive or flammable gases in the room.
- The compressor is suitable for use in dry rooms. In humid environments, use is not permitted.
- Place the compressor on the rubber feet on the rear wall of the compressor during operation.

Mounting the stand

- The enclosed feet must be mounted as shown in Fig. 4.

Assembly of the wheels

- The enclosed wheels must be mounted as shown in Fig. 5 and Fig. 6.

Assembly of the Y-quick coupling

- Screw the Y-quick coupling (5) to the compressed air outlet of the tank. The Y-quick coupling is already prepared with a sealing tape on the thread for screwing.

Mains connection

- Before commissioning, make sure that the mains voltage matches the operating voltage according to the machine rating plate. Long cables, as well as extensions, cable drums, etc. cause voltage drops and can prevent motor startup. At low temperatures below + 5 ° C, the motor startup is endangered by stiffness.

ON/OFF switch (Fig. 2)

- Pressing the ON/OFF switch (8) turns on the compressor. To turn off the compressor, press the ON/OFF switch (8) again. After use, switch off the device and unplug it to prevent unintentional start-up.

Pressure setting (Fig. 1/2)

- The pressure regulator (7) can be used to adjust the pressure on the pressure gauge (6).
- The setted pressure can be taken from the quick coupling (5).

Pressure switch setting

- The pressure switch is factory set.
Switch-on pressure: see technical data
Switch-off pressure: see technical data
- Before use, check whether the compressor shuts off when the switch-off pressure is reached. Then check by removing compressed air with a compressed air tool if the compressor starts again when the pressure drops below the switch-on pressure.

Spiral hose with quick coupling (Fig. 3b, 8-9)

Connecting the compressed air hose:

- Push the nipple of the compressed air hose into the quick connector of the Y adapter until it clicks into place, the sleeve will automatically jump forward.

Connecting the pneumatic tool:

- Push the nipple of your compressed air tool into the quick coupling of the compressed air hose, the sleeve will automatically jump forward.

Separate:

- Pull back the respective sleeve and remove the compressed air tool or compressed air hose.
- **Attetion!** When releasing the quick coupling, the coupling piece must be held in place to avoid injury from the recoiling hose.

Tire inflator with adapters (Fig. 3b)

- Working pressure in bar: see technical data

Application:

- The tire inflator allows a simple and accurate filling of tires. The pressure gauge is used to control the tire pressure. With the integrated drain valve (e) it is possible to lower too high tire pressure. The tire inflator is equipped with a valve adapter for tire valves.
- Attention, the pressure gauge is not calibrated! Please check the tire pressure immediately after filling, e.g. at a gas station.

Use as blow-out gun

- To use the tire inflator as a blow gun, first unscrew the hose with the car tire valve adapter. Now the outlet adapter (12) can be screwed to the tire filling knife.

Application:

- For cleaning/blowing out cavities or hard-to-reach areas, as well as for cleaning dirty equipment. The infinitely operable trigger allows precise metering of compressed air.

Instructions for the 5 parts adapter set (Fig. 3b)

- The following overview shows the correct use of the adapters for the various valves.

Ball needle (Item 13a)



- Application: For inflating balls.
- The ball needle can be used to inflate different balls.
TIP: To avoid damaging the valve, you should moisten the ball needle slightly before inserting it.

Additional adapter (item 13b)

- Application: The adapter can be used for filling air mattresses and the like with narrow opening.

Valve adapter (Item 13b)

- Application: Fits flash valves of bicycle tires.
- The flash valve adapter allows easy filling of bicycle tires.

Conical universal adapter (Item 13c)

- Application: The universal adapter can be used for filling air mattresses and the like.

Additional adapter (item 13d)

- Application: The adapter can be used for filling air mattresses and the like with wider opening.

Valve adapter (item 13e)

- Application: Fits valves of bicycle tires.
- This valve adapter allows easy filling of bicycle tires



Instructions for the 3 parts adapter set (Fig. 3b)

Adapter 1 (Pos 18)

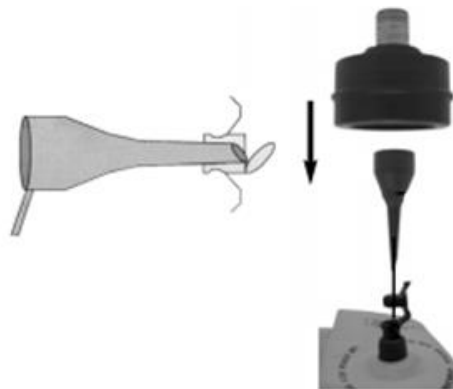

- Application: for all valves with an inside diameter from 0.315 in (8 mm).
- You can use the adapter for example for air mattresses, pools or boats.
- TIP: Insert the adapter into the valve (see picture).
- Important! The valve cap must be opened slightly by pressing it together

Adapter 2 (Pos 18)



- Application: for use with commercially available screw valves.
- You can use this adapter for all standard bathing boats, kayaks or other large items, such as pools, which are equipped with a screw valve.

Adapter 3 (Pos 18)



- Application: For exhaust valves.
- An exhaust valve can be found along with other valves (standard valve, screw valve, ...) on many large volume items.

Behavior in emergency situations

1. Stop the work process
2. Turn off the device.
3. Disconnect the power plug

After use

1. Turn off the device.
2. Disconnect the power plug
3. Disassemble all accessories from the device, such as hose, tire filling knife, etc.
4. Allow the unit to cool before repairing or cleaning.
5. Check the device for possible damage.

7. Cleaning and maintenance

7.1 General

- Disconnect the mains plug from the socket before any cleaning or maintenance work!
- Prior to all cleaning and maintenance work, the device must be depressurized.
To do this, use the tire inflation meter as a blow-out gun and operate the trigger until no more air escapes.
- **Risk of explosion!** The compressed air tank or the connected tools may be under pressure; improper handling may cause a risk of explosion.
 - Completely bleed the compressor before cleaning or servicing the compressor.
 - Service the compressor regularly and have the necessary maintenance and repair work carried out immediately by a recognized specialist workshop.
- **Risk of burning!** The compressor becomes hot during operation and you can burn yourself (especially on pressure tank "2")
 - Allow the compressor to cool down completely before cleaning or servicing the compressor.
- **Danger of short circuit!** Water or other liquids that have entered the housing may cause a short circuit.
 - Disconnect the mains plug before any cleaning or maintenance work from the socket.
 - Never immerse the compressor in water or other liquids.

- Do not use a high-pressure cleaner to clean the compressor.
- Make sure that no water or other liquids get into the housing.
- Disconnect compressed air hose and tools from the compressor before cleaning.

7.2 Clean the compressor

1. Set the ON/OFF switch to the "0" position.
2. Disconnect the power plug from the wall outlet before cleaning.
3. Allow the compressor to cool completely.
4. Vent the compressor via the connected compressed air tool.
5. Disconnect connected air tools from the compressor before cleaning. Hose and spray tools must be disconnected from the compressor before cleaning. The compressor must not be cleaned with water, solvents or the like.
6. Remove condensation water as described in the chapter "Draining condensation water".
7. Wipe the guards, air vents, and motor housing with a clean cloth or blow with compressed air at low pressure.
8. Wipe the compressor with a damp cloth and mild detergent, or blow it out with compressed air at low pressure.
9. Wipe all parts completely dry.
 - Keep protective devices as dust and dirt free as possible.
 - We recommend that you clean the unit immediately after each use. Clean the device regularly with a damp cloth and some soft soap. Do not use detergents or solvents; these could attack the plastic parts of the device. Make sure that no water can get inside the unit.

7.3 Drain condensation (Fig. 7)

- **Risk of damage!** When compressed air is in the compressed air tank, the condensed water is expelled with high pressure when opening the drain valve.
 - Reduce the vessel pressure before opening the condensate drain valve.
 - Always carefully open the condensate drain valve and never fully open the drain valve.
 - **Environmental risk!** If the condensation water enters the sewage system, it will lead to environmental pollution.
 - Dispose of condensed water only as special waste in accordance with local regulations.
 - For permanent durability of the pressure vessel (2), drain the condensate water by opening the drain valve (1) after each operation.
1. Set the ON/OFF switch to the "0" position.
 2. Disconnect the power plug from the power outlet.
 3. Allow the compressor to cool completely.
 4. Vent the compressor via the connected compressed air tool.
 5. Disconnect connected pneumatic tools from the compressor.
 6. Turn down the tap to open the drain valve.
 7. In addition, tilt the tank so that the drain valve is the lowest point in the tank and the condense water can drain off completely.
 8. Then turn the tap upwards to close the drain valve.

7.4 Check compressor

- Regularly check the condition of the compressor. Check whether:
 - the ON/OFF switch is undamaged,
 - the locking screw of the condensate drain valve is working properly,
 - the accessories are in perfect condition,
 - the power cord and the power plug are undamaged,
 - the ventilation slots are free and clean. If necessary, use a brush or a soft scrubber to clean it.

7.5 Exchange mains connection cable

- **Risk of electric shock!** If the power cord is damaged or improperly installed, there is a risk of electric shock.
 - The mains connection cable may only be replaced by a qualified specialist to avoid hazards.

7.6 Carbon brushes

- If excessive sparking occurs, have the carbon brushes checked by a qualified electrician. Danger! The carbon brushes may only be replaced by a qualified electrician.

7.7 Safety valve

- The safety valve is set to the maximum pressure of the pressure tank. It is not allowed to adjust the safety valve.
- The safety valves are designed and manufactured in such a way that a maximum of quality and service friendliness is achieved. This results in a minimum need for care and maintenance for the safety valves. Nevertheless, there may be leaks/contamination. Corresponding repairs/cleanings should only be carried out by trained personnel/specialists.

7.8 Maintenance

- There are no further serviceable parts inside the device.

7.9 Transportation

- **Risk of electric shock!** If you transport the compressor during operation, there is a risk of electric shock.
 - Switch off the compressor before each transport and disconnect the mains plug from the socket.
 - **Risk of damage!** If you improperly transport the compressor or turn it upside down, it may be damaged or liquids may leak.
 - Only transport the compressor over short distances in an upright position.
 - Secure the compressor against impact and vibration when transporting the compressor in a vehicle.
 - Always use the transport handle for transportation.
 - Do not use hooks or ropes to lift the compressor.
1. Disconnect the power plug from the socket.
 2. Allow the compressor to cool completely.
 3. Vent the compressor via the connected compressed air tool.
 4. Grasp the compressor for transport on the transport handle.
 5. Secure the compressor with ropes when transporting it in a vehicle or trailer.
 6. Protect the device against unexpected shocks or vibrations.

7.10 Storage

- **Risk of damage!** Incorrect or improper storage may damage the compressor.
 - Before storing, disconnect the mains plug from the socket to disconnect the compressor from the mains.
 - Store the compressor and all connected compressed air tools only in a de-aerated condition.
 - Always store the compressor in a dry environment.
 - Always store the compressor standing upright and do not tilt it.
 - Always store the compressor in a room inaccessible to children.
 - Always store the compressor so that it cannot be put into operation by unauthorized persons.

1. Disconnect the power plug from the socket.
2. Allow the compressor to cool completely.
3. Vent the compressor via the connected compressed air tool.
4. Clean the compressor and remove the condensation as described in the chapter "Cleaning and maintenance".
5. Store the compressor on a flat and dry surface in a dark, dry and frost-free room, inaccessible to children. The optimum storage temperature is between 5°C and 30°C.
6. Cover the compressor to keep it from dust and the like when not in use for a long time. Store the device in its original packaging.

8. Troubleshooting

Problem	Cause	Solution
Compressor is not running.	<ol style="list-style-type: none"> 1. Mains voltage not available. 2. Mains voltage too low. 3. Outside temperature too low. 4. Motor overheated. 	<ol style="list-style-type: none"> 1. Check the cable, power plug, fuse and socket. 2. Make sure that the mains voltage matches the information on the type plate. Avoid too long extension cords. Use extension cable with sufficient wire cross section. 3. Do not operate below +5°C outside temperature. 4. Allow the motor to cool down, if necessary, eliminate the cause of the overheating.
Compressor is running, but no pressure.	<ol style="list-style-type: none"> 1. Check valve (see No. 34 in exploded view on page 12) leaking. 2. Seals broken. 3. Drain valve for condensed water leaking. 	<ol style="list-style-type: none"> 1. Have the check valve replaced by a qualified specialist! 2. Check seals, replace damaged seals with a specialist workshop. 3. Close valve by hand. Check gasket on bolt, replace if necessary.
Compressor is running, pressure is displayed on the manometer, but tools are not running.	<ol style="list-style-type: none"> 1. Hose connections leaking. 2. Quick coupling leaking. 3. Too little pressure set on the pressure regulator. 	<ol style="list-style-type: none"> 1. Check compressed air hose and tools, replace if necessary. 2. Check quick coupling, replace if necessary. 3. Turn up the pressure regulator further.

9. Disposal instruction

9.1 Disposal of the packaging

- Please make reference to the guidelines and standards for appropriate disposal of the packaging valid in your region. In part, the package may consist of plastic bags - watch this respect, with special care to ensure that this is not out of the reach of children. There is a risk of suffocation!

9.2 Disposal of waste equipment

- Equipment must be disposed of in accordance with the rules and regulations of the local waste disposal.

9.3 Meaning of the "dustbin"



Protect our environment; electrical appliances do not belong in household waste. Use the provided for the disposal of electrical equipment collection points and enter your electrical and electronic equipment that you no longer use. They help ensure that the potential effects of incorrect disposal on the environment and human health to be avoided. So, do your part to recycle, recycling and other forms of recovery of waste electrical and electronic equipment. Information on where the devices are disposed of, please contact your local authorities or local Governments.

Our customer service number: +49 (0) 931-45232700

EU Declaration of Conformity

We,

Canbolat Vertriebs GmbH, Gneisenaustraße 10-11, 97074 Würzburg, Germany,

Hereby declare that the product named below, seen its design and construction as well as according to our sales, has been complied with the relevant and basic health and safety EU-requirements.

Name of the product: Air Compressor 50 L

Model Nr.: AR-HE-LK150050S

Art. Nr.: 4260551588105

If the product has any modification not allowed by us, this declaration loses its validity.

Tested acc. to:

EU Standard:

Machinery (2006/42/EC)

EN 1012-1: 2010

EMC directive(2014/30/EU)

EN 61000-6-1: 2007

EN 61000-6-3: 2007/A1:2011

Directive 2000/14/EC, ANNEX VI, and Directive 2005/88/EC

Date/Manufacturer Signature/Location:

Würzburg, 08.06.2021



Identification of the signatory:

Korhan Canbolat, head of the company

Authorised representative for the technical documentation:

Korhan Canbolat

Office address:

Canbolat Vertriebs GmbH

Gneisenaustraße 10-11

D-97074 Würzburg

Return address can be found in the imprint: <https://www.arebos.de/impressum/>

VAT identification number: DE 263752326

Court of the Commercial Register is Würzburg, HRB 10082

WEEE Reg.-No. DE 61617071