

# AREBOS

## Upright Vacuum Cleaner Eco

AR-HE-HSSER/S/B



Please follow all security measures in this user's manual to ensure a secure use.



Thank you for trusting in AREBOS.

Thank you for purchasing our product. Please read the operating instructions carefully before using the product for the first time. If you give the product to a third party, this manual must be handed over with it. Keep the instruction manual for future reference. The drawings in this manual may not match the physical objects. Please refer to the physical objects.

## Security Instructions

### Explanation of the symbols



By means of a CE marking, it can be recognized that a product complies with the legal requirements of European legal standards and therefore may be traded within the European Community.



This product **must not** be disposed of with household waste!



**Warning!** Read the safety instructions carefully. Failure to follow the safety precautions could result in serious injury or damage. Keep the operating instructions in a safe place.



Protective insulated housing (protection class II)!



Take special care when using this article.

### Safety Precautions

- Read the operating instructions carefully before putting the appliance into operation and keep the instructions including the warranty, the receipt and, if possible, the box with the internal packing. If you give this device to other people, please also pass on the operating instructions.
- The appliance is designed exclusively for private use and for the envisaged purpose. This appliance is not fit for commercial use.
- The mains adaptor is only suitable for use in dry rooms.
- Check if the output current, voltage and the polarity of the mains adaptor match the information on the connected appliance!
- Do not touch the connected mains adaptor with wet hands!
- If necessary, disconnect the appliance from the power adaptor.

- Ensure that the cable of the mains adapter does not become kinked, jammed, driven over or come into contact with heat sources.
- Do not use a damaged mains adapter.
- Do not repair the appliance yourself but visit an authorized specialist.
- The device and the mains lead have to be checked regularly for signs of damage. If damage is found the device must not be used.
- Use only original spare parts.
- In order to ensure your children's safety, please keep all packaging (plastic bags, boxes, polystyrene etc.) out of their reach.

### **Special Safety Instructions for this Device**

- This appliance can be used by children aged from 8 years and above and persons with reduced physical, sensory or mental capabilities or lack of experience and knowledge if they have been given supervision or instruction concerning use of the appliance in a safe way and understand the hazards involved.
- Children shall not play with the appliance.
- Cleaning and user maintenance shall not be made by children unless they are older than 8 years and supervised.
- Keep the appliance and its cord out of reach of children less than 8 years.
- The device is intended for use with safety extra-low voltage.
- Connect only to a power supply according to the specifications on the rating label.
- If the connection cable of this device has been damaged, it must be replaced with a special connection cable available from the manufacturer or its customer service.
- Do not suck in combustible substances or liquids!
- Avoid vacuuming sharp or pointed objects!
- Never vacuum without the filter installed.

### **Special Safety Information Concerning the Rechargeable Built-in Battery**

- The device contains rechargeable lithium-ion batteries that may not be replaced by the user.
- Risk of explosion in case of improper replacement of the rechargeable battery. Replace only by the same or an equivalent type.
- Do not expose the rechargeable built-in battery to hard impacts or pressure. Do not drop the device!
- Do not expose the device to intense heat such as sunlight.
- Also keep the device away from heat sources like radiators, stoves, etc.!
- The battery must be removed from the appliance before it is scrapped.
- The battery is to be disposed of safely.
- The appliance must be disconnected from the supply when removing the battery.
- The ambient temperature should be between 0 °C and max. 45 °C.
- Heat damages the rechargeable battery. Increasingly lower temperatures reduce the capacity and the life of the rechargeable battery.
- Do not charge the rechargeable battery unsupervised.
- Use only the mains adapter included in the scope of deliveries.
- Disconnect the power supply unit from the mains when you will not use the device for a longer time.

## Overview of the Components / Delivery Scope

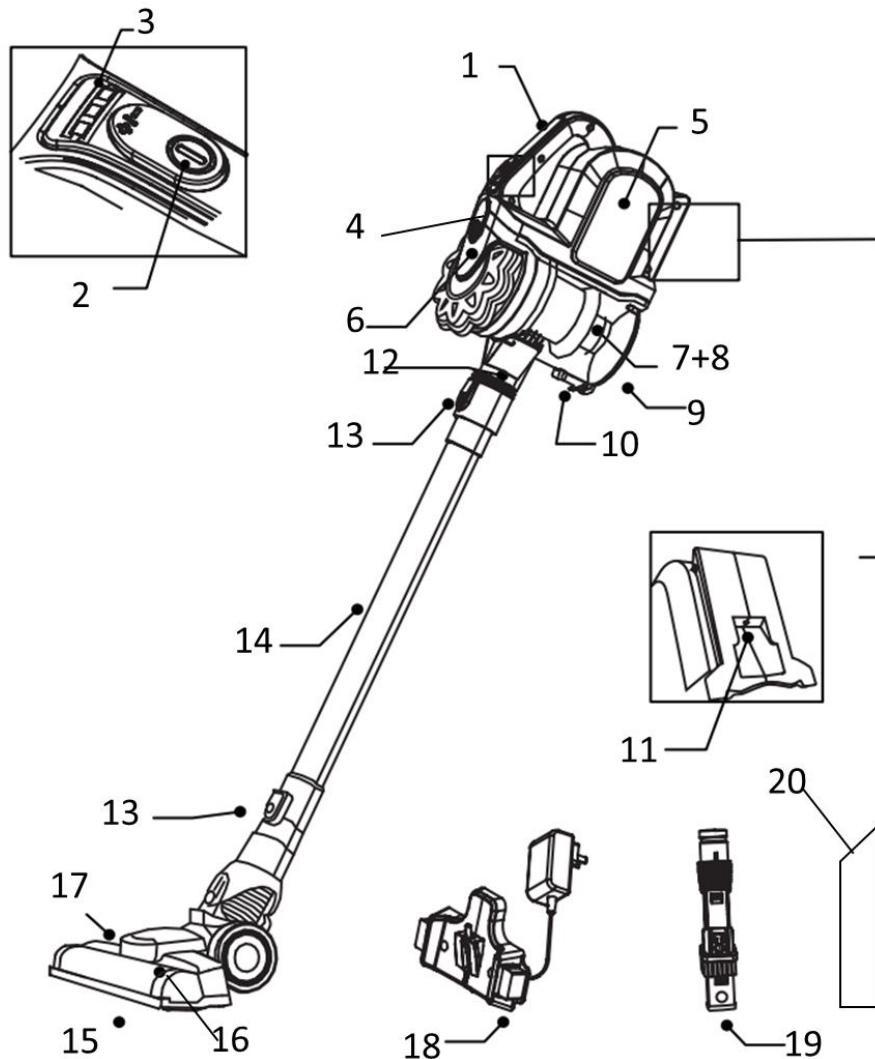

1. Main Handle
2. Power Switch
3. Battery Status Indicator
4. Dust Container Release Button
5. Handheld Vacuum Cleaner
6. Dust Container Upper Cover
7. Dust Filter Assembly
8. Dust Container (Cup)
9. Dust Release Button
10. Dust Release Button
11. Charging Socket
12. Suction inlet
13. Extended Tube Release Button
14. Extended Tube
15. Floor Brush
16. Rotating Brush Release Button

- 17. Floor Brush LED Lamp
- 18. Wall mountable Charger/Adapter
- 19. Combined Crevice Nozzle
- 20. Crevice Nozzle

### Unpacking the Device

1. Remove the device from its packaging.
2. Check the delivery scope for completeness.
3. Check the device for any transport damage, in order to prevent hazards.
4. Remove the transport lock from the multifunction button.

**NOTE:** In case of any transport damage, contact your dealer immediately. Do not use a damaged device!

## Notes on Use

- The device is especially suitable for quickly vacuuming small amounts of dry dirt or dust.
- The device is operated via charged battery. Charging is done via the supplied power supply unit.
- Direct power supply via mains adapter is not possible.

### Multifunction Button

Use the multifunction button to turn the device on and off.

Also select a power level with this button.

Press once = Turn on the device, low power level

Press twice = Select high power level

Press three times = Turn off the device

## Start-up

### Suction Tube

- Insert the suction pipe with the two contact pins into the connection on the hand unit. It must audibly engage.
- To disconnect the suction pipe, press the release (14) and pull out the pipe at the same time.

### Floor Nozzle with Turbo Brush

The floor nozzle is suitable for any floor covering. During operation, the LEDs on the floor nozzle light up for better visibility in dark areas.

**Caution: You cannot replace the LEDs.**

- Slip the lower end of the suction pipe onto the connector on the floor nozzle. Pay attention to the contact pin. The suction pipe must audibly engage.
- To release the suction pipe, push the release (11) away from the suction pipe and pull out the pipe at the same time.

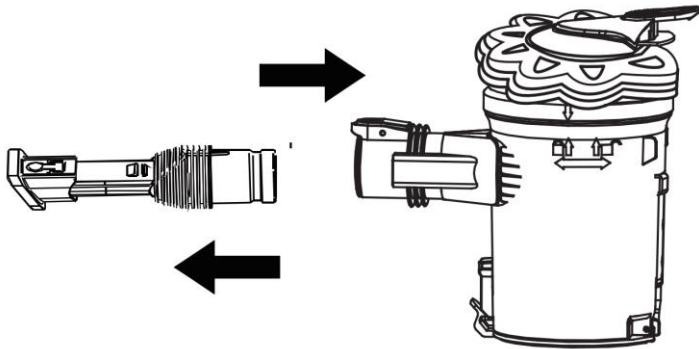
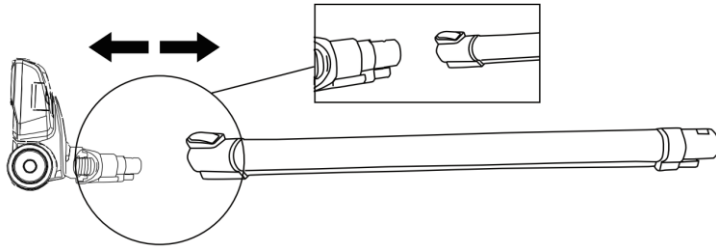
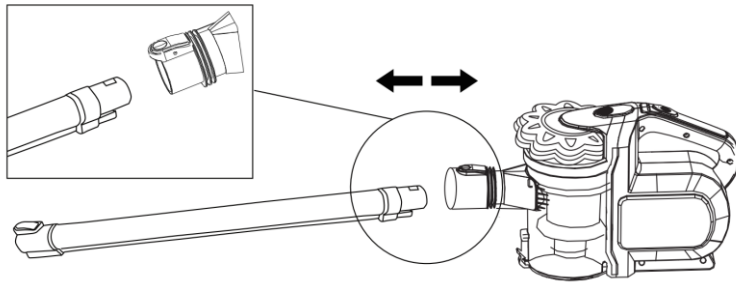

### Nozzle Attachments

You can attach nozzle attachments directly to the hand unit or to the already installed suction pipe.

#### Connection at the Hand Unit

- Insert a nozzle attachment with the marking facing up into the connection at the hand unit. It must audibly engage.
- To disconnect the nozzle attachment, press the release (14) and pull out the attachment at the same time.

#### Connection to the Suction Tube

You need the adapter (15) for connection to the suction pipe.

- Insert the adapter with the angular side into the lower end of the suction pipe.
- Now you can slip a nozzle attachment onto the round side of the adapter.
- For removal of the nozzle attachment and the adapter, just pull the parts off.

#### Combined Crevice / Brush Nozzle

With this nozzle, you can selectively vacuum corners and slots.

Use the nozzle with locked brush to prevent scratching of the surface to be cleaned.

- For this, press the button and push the brush to the end of the nozzle. It must engage.
- Press the button again to unlock the brush.

## Assembly the Wall Holder

### Inserting the Plug of the Power Supply Unit

If you want to use the wall holder also as the charging station, attach the plug of the power supply unit first. Refer to the illustrations (A to C) on page 21.

**NOTE:**

- Turn the plug at the metal end, not at the cable. Use a pliers if necessary.
  - There is an opening at the rear of the wall holder. You can the plug additionally with a finger through this opening.
1. Set the plug of the power supply unit with the flattened side into the wall holder. (Fig. A)
  2. Turn the plug of the power supply unit by 90°. It must sit solidly in the holder and sliding no longer shall be possible. (Fig. B)
  3. Fix the cable in the cable guide. (Fig. C)

### Fastening the Wall Holder

**WARNING:** Make sure beforehand whether there are cables in the wall which could be damaged!

**CAUTION:** Place the wall holder so that the appliance is not exposed to direct sunlight or other heat sources.

**NOTE:** A power outlet must be near.

1. Measure the height for the wall holder. Hold the vacuum cleaner against the wall with the suction pipe and the floor nozzle installed.
2. Hold the wall holder against the wall as shown on page 21.  
Mark 2 drill holes.
3. Drill the holes and insert the wall plugs into the wall.
4. Insert the screws through the holes of the wall holder.
5. Tighten the screws with a screwdriver hand-tight.

## Charging the Battery

1. Turn off the device.
  2. Connect the power supply unit with the connection socket (5). If you have prepared the wall holder as a charging station, suspend the appliance from the wall holder.
  3. Connect the mains adapter to a certified wall socket.
- Charge the device for approx. 5 hours before first-time use.

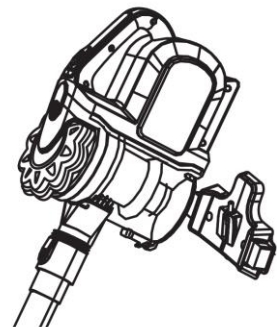



**NOTE:**

1. The LED charge indication shows the charging status of the rechargeable battery. (25 %, 50 %, 100 %)
2. The appliance has electronic charge control, which prevents overcharging.
3. Charging has been completed when all 3 LEDs are lit.
4. The LEDs switch off after a while.
5. It is normal for the device to heat up during charging.
6. The rechargeable battery must be charged when the LED charge indication shows only 25 % of capacity.
7. Disconnect the power supply unit from the outlet once the rechargeable battery has been charged completely.



**NOTE:**

**Even when switched off, the rechargeable battery discharges continuously. If the device is out of use for a longer period of time, charge the rechargeable battery at least once every 6 to 12 weeks.**

## Using the Device

You can use the appliance as a floor vacuum cleaner or as a handheld and upright vacuum cleaner (basic unit).

1. Disconnect the appliance from the mains when changing the accessory.
2. Turn on the device.
3. Select a power level.

**NOTE:**

**We recommend the higher power level for using the appliance with the floor nozzle.**

## End of Operation

1. Turn off the device.
2. If you have already installed the wall holder, hang up the vacuum cleaner. You can attach the crevice and brush nozzle at the left and the right of the vacuum cleaner.

## Maintenance

### Emptying the Dust Collector

1. Disconnect the appliance from the power supply unit.
2. If necessary, remove the suction tube or the nozzle attachment from the appliance.
3. Hold the appliance with the bottom plate of the dust collector over a dustbin.
4. Empty the contents of the dust collector. Slide the opener of the dust collector downwards to open the bottom plate.
5. Then close the base plate again. The lock on the dust collector must engage.

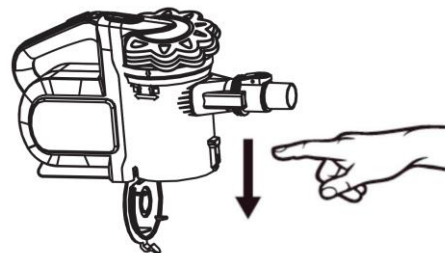



## The Filter System

Your appliance features 3 filters. The common dust bag system has been replaced by a transparent dust collector.

The higher flow speed of the collector allows for heavy dirt and smallest floating particles to be separated from the “sucked-in air”.

It is thus not necessary to buy dust bags.

The filters must be cleaned periodically.

### CAUTION:

- **Never wash the filter in the washing machine.**
- **Do not use a hairdryer for drying.**
- **Only put the appliance back into operation when all filters are completely dry and correctly assembled.**

## The Filter Unit

The filter unit is composed of:

- HEPA filter
- Coarse filter

Proceed as follows to clean the filter unit:

1. Empty the dust container as described above.

(Steps 1 - 5)

### 2. Disassembly of the filter unit

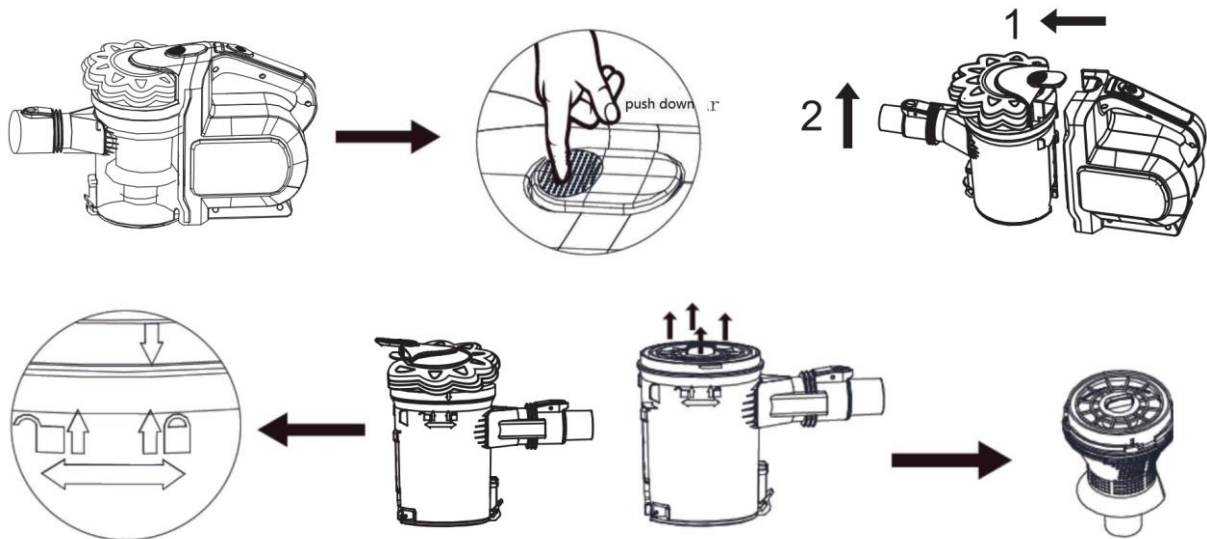

2.1. Press the dotted area of the button (1) to disconnect the dust container from the motor housing.

2.2. Turn the cover of the dust container in the direction.

Remove the cover.

2.3 Pull the filter unit from the dust container.

2.4 Turn the HEPA filter to remove it from the coarse filter.

3. You can brush out the HEPA filter. In case of heavy staining, clean the filters under running water.

4. Let the filters air-dry completely before refitting them!

5. Wipe the dust collector with a damp cloth and then wipe it dry.

## 6. Assembly of the filter unit

6.1 The HEPA filter has 3 guide lugs. Set the largest guide lug into the largest recess of the coarse filter. Tighten the HEPA filter by turning it clockwise. It must audibly engage.

6.2 Set the filter unit into the dust container. The rounded guide lug must sit exactly in the rounded recess.

6.3 Reattach the cover to the dust container. Set the arrow on the cover just over the arrow at the side of the symbol.

6.4 Tighten the cover in the direction. It must audibly engage.

6.5 Reattach the dust container to the motor housing. Set the dust container first at the bottom part to the motor housing, so that the electric contacts are matched. Then engage it to the top. For this, press the smooth area of the button (1).

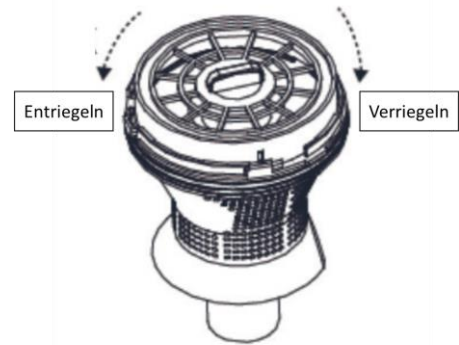

### Outlet Filter

The appliance is also equipped with an outlet filter. It is on the right side of the appliance.

**CAUTION: You cannot remove this filter.**

## Cleaning

- **WARNING: Always disconnect the appliance from the power supply unit before cleaning!**
- **Under no circumstances should you immerse the motor housing in water in order to clean it. Otherwise this might result in an electric shock or fire.**
- **Do not use a wire brush or any abrasive items.**
- **Do not use any acidic or abrasive detergents.**
- **The single components are not dishwasher-safe.**
- Wipe the casing with a damp cloth.
- You can wipe the mains adapter unit with a dry cloth.

### Floor Nozzle

1. Disconnect the floor nozzle from the suction pipe.
2. Turn the floor nozzle around, so that you see the lower side.

Turn the lock of the brush roller on the left side counterclockwise with tool to unlock the brush roller. the lock of the brush roller on the left side.

3. Pull out the brush roller.
4. Remove threads and hair wound to the brush. Use scissors, if required.

#### 5. Assembly:

Refer to the adjacent figure.

- 5.1 Set the brush roller at position (1). Make sure that the triangular recess on the brush roller is positioned correctly.
- 5.2 Return the bearing of the brush roller into the housing of the floor nozzle (position 2).
6. Close the lock of the brush roller. It must audibly engage.

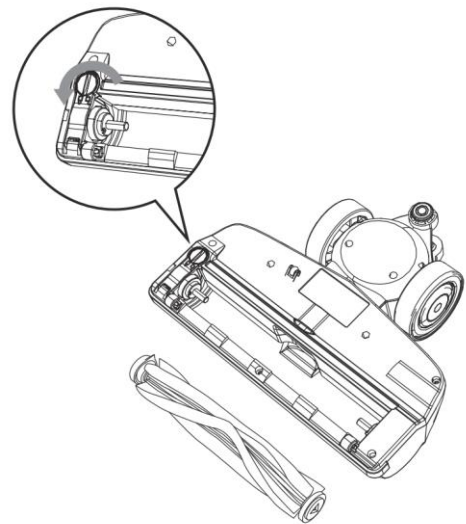

## Dust Container with Filter Unit

Please read the chapter “Maintenance” for cleaning of these components.

## Storage

- Clean the appliance as described and allow it to dry.
- You can use the previously installed wall holder for storage.
- We recommend that you keep the appliance in the original packaging if it will not be used for long periods.
- **NOTE** concerning the life of the rechargeable battery:  
Even when switched off, the rechargeable battery discharges continuously. When the device is out of use for a longer period of time, charge the rechargeable battery at least once every 6 to 12 weeks.
- Always store the appliance out of the reach of children in a dry, well ventilated place.

## Troubleshooting

Problem	Possible cause	Remedy
The device does not function.	<ul style="list-style-type: none"> <li>- The rechargeable battery is empty.</li> <li>- The power supply unit is connected.</li> <li>- The rechargeable battery is defect.</li> </ul>	<ul style="list-style-type: none"> <li>- Charge the battery.</li> <li>- Disconnect the appliance from the power supply unit.</li> <li>- Contact our service or your dealer.</li> </ul>
Weak suction power.	<ul style="list-style-type: none"> <li>- The battery is nearly discharged.</li> <li>- The dust container is full.</li> <li>- The filters are dirty.</li> </ul>	<ul style="list-style-type: none"> <li>- Charge the battery.</li> <li>- Empty the dust container.</li> <li>- Clean the filters as described under „Maintenance “.</li> </ul>
Noise during operation.	A foreign body has been sucked into the floor nozzle.	Remove the foreign body. If required, disconnect the floor nozzle from the suction pipe.
The floor nozzle with turbo brush is not operating.	<ul style="list-style-type: none"> <li>- The brush roller is blocked by dirt.</li> <li>- Incorrect assembly of suction pipe and/or floor nozzle.</li> </ul>	<ul style="list-style-type: none"> <li>- Clean the floor nozzle as described under „Cleaning “.</li> <li>- Check the assembly.</li> </ul>
Dust escapes from the dust container.	The dust container is not closed correctly.	Check the installation of the filter unit, the cover, and the base plate.
The rechargeable battery does not keep the charge.	The rechargeable battery has reached the end of its life.	Contact our service or your dealer.

## Technical Specifications

<b>Model</b>	<b>AR-HE-HSSE/R/S/B</b>
Power	200 W
Power supply	100V-240V / 50Hz-60Hz
Battery capacity	2200mAh, 21,6V
Battery type	LI-ION battery
Charging time	4-5 hours
Speed levels	2: high / low
Runtime in high speed mode	15 minutes
Runtime in low speed mode	55 minutes
Power consumption	12 KPA
Filter	HEPA
Brush type	electrical
Dust container volume	0,8 l
Engine type	Normal electrical motor
Energy class	A+++
Protection class	III
Sound level	68db
Dimensions (L x W x H)	1060 mm x 210 mm x 100 mm
Net Weight	1,4 kg

## Environmentally friendly disposal

**Warning Danger of suffocation!** Packaging material is dangerous for children. Never let children play with packaging material.

### Disposal and packaging

- The packaging of your unit consists of materials that are necessary to guarantee effective protection during transport. These materials are fully recyclable and therefore reduce the environmental impact. Dispose of the packaging in a bin for recyclable materials.

### Disposal of old equipment

- Old appliances must be disposed of in accordance with the guidelines and regulations of the local waste disposal authority. Check with your local administration for the address of the nearest recycling centre and deliver your appliance there.



The symbol of the crossed-out dustbin on a Waste electrical or electronic equipment indicates that it must not be disposed of with household waste at the end of its life. Collection points for waste electrical and electronic equipment are available free of charge in your area. You can obtain the addresses from your city or local government. You can find out about other return options created by us on our website [www.arebos.de](http://www.arebos.de).



The separate collection of Waste electrical or electronic equipment is intended to enable the reuse, recycling or other forms of recovery of Waste electrical or electronic equipment and to avoid the negative consequences of disposal on the environment and human health.

### Notes on battery disposal

The symbol of the crossed-out dustbin on batteries or accumulators indicates that they must not be disposed of with household waste at the end of their service life. If batteries or accumulators contain mercury (Hg), cadmium (Cd) or lead (Pb), you will find the respective chemical symbol below the symbol of the crossed-out trash can. You are legally obliged to return old batteries and accumulators after use. You can do this free of charge in a retail store or at another collection point near you. Addresses of suitable collection points can be obtained from your city or local government.

**Our customer service number: Tel. +44 (0) 208 068 5604**

**Fax: +49 (0) 931 4523 2799 / E-Mail: [info@arebos.de](mailto:info@arebos.de)**

Office address: Canbolat Vertriebs GmbH • Gneisenaustraße 10-11 • 97074 Würzburg

**Return address** can be found in the imprint: <https://www.arebos.de/impressum/>

## Revocation/Return

- Check the product for transport damage. Immediately report any damage to the transport company that delivered the product.
- **Revocation/Return:** Please note that the full purchase price can only be refunded if the returned goods are unused, new and in their original packaging.

## Declaration of Conformity EU

We, the

Canbolat Vertriebs GmbH, Gneisenaustraße 10--11, 97074 Würzburg, Germany

hereby declare that the equipment described below, by virtue of its design and construction and in the versions placed on the market by us, complies with the relevant essential health and safety requirements of the EU directives.

Name of the product: AREBOS Upright Vacuum Cleaner Eco

Model number: AR-HE-HSSE/R/S/B

Article number: 4260627423958 (red); 4260627423965 (black); 4260627423972 (blue)

Should the appliance be modified without our consent, this declaration of conformity will lose its validity.

Verified acc. to:

Standard EU:

EN 60335-2-2:2010+A11:2012+A1:2013

EN 60335-1:2012+A11:2014

EN 62233:2008

(EMC) 2014/30/EU

EN55014-1: 2006+A1: 2009+A2: 2011

EN 55014-2: 1997+A1: 2001+A2: 2008

EN 55014-2: 2015

EN 61000-3-2: 2014

EN 61000-3-3: 2013

2011/65/EU (ROHS)

Date/Manufacturer Signature/Location:

Würzburg, 24.02.2022



Signature:

Dipl.-Inform. (Univ.) Korhan Canbolat, Managing Director

Representative of these instructions for use/technical data:

Dipl.-Inform. (Univ.) Korhan Canbolat, Managing Director

Office address:

Canbolat Vertriebs GmbH

Gneisenaustraße 10-11

D-97074 Würzburg

Return address can be found in the imprint: <https://www.arebos.de/impressum/>

VAT identification number: DE 263752326

Court of the Commercial Register is Würzburg, HRB 10082

WEEE Reg.-No. DE 61617071