

AREBOS

Scooter

AR-HE-TRP/R/B/S



Please follow all security measures in this user's manual to ensure a secure use.

Thank you for trusting in AREBOS.

Table of Contents

1 Safety instructions.....	3
1.1 Explanation of the symbols	3
1.2 Intended Use	3
1.3 General safety instructions	4
2 Delivery Content and Technical Data ..	6
2.1 Delivery Content.....	6
2.2 Technical data	6
3 Assembly	6
Unfolding (Fig.1)	6
Mounting the grips (Fig. 2).....	7
Adjusting the height of the steering column (Fig. 3)	7
Steering head bearing (Fig. 4)	8
Folding the Scooter for Transport (Fig 2,3,5,6,7)	8
Riding, braking, parking (Fig. 8).....	8
4 Maintenance, Cleaning and Storage....	9
4.1 Maintenance	9
4.2 Cleaning and Storage	10
5 Environmentally friendly disposal.....	10
5.1 Disposal and packaging	10
5.2 Disposal of old equipment	10
Declaration of Conformity	11

Thank you for purchasing our product. Please read the operating instructions carefully before using the product for the first time. If you give the product to a third party, this manual must be handed over with it. Keep the instruction manual for future reference. The drawings in this manual may not match the physical objects. Please refer to the physical objects.

1 Safety instructions

1.1 Explanation of the symbols



Warning! Read the safety instructions carefully. Failure to follow the safety precautions could result in serious injury or damage. Keep the operating instructions in a safe place.



Warning! When using this product, wear personal protective equipment (safety helmet and clothing).



Warning! Danger of crushing hands!



Warning! This signal word indicates a hazard with a medium degree of risk which, if not avoided, could result in death or serious injury.



Suitable for users with a body weight over 20 kg up to 100 kg.

1.2 Intended Use

- This product is intended for private, non-commercial use only.
- The scooter is a leisure product, not a toy, and should be used by one person weighing between 20 kg and 100 kg.
- It is designed for outdoor use with a maximum load capacity of 100 kg.
- The product is not suitable for jumps, stunts, or tricks.
- It may not be used on public roads. Inform yourself about statutory regulations before using

it.

- The scooter should be used only on sidewalks and paved paths.
- Before using, check and follow local regulations regarding scooter use.
- It contains small parts that could be swallowed by children and requires concentration and good motor skills.
- Do not make any unauthorized modifications to the product.

Using the product in any way other than its intended use or making unauthorized modifications can lead to injury and damage. The manufacturer does not accept liability for damages resulting from improper use.

1.3 General safety instructions

Important note for parents:

This manual contains important information relating to your child's safety. It is your responsibility to review this information with your child and make sure they are fully aware of all the information and warnings within the manual. Please carefully read this manual before you commence assembly of this scooter and review this information with young riders before the ride.

WARNING! Suffocation risk for children!

- **Do not allow children to play with the product or the packaging materials unsupervised.**

WARNING! Risk of Injury!

- Improper use of the scooter can lead to serious injuries.
- Carefully fold and unfold the scooter, paying special attention to your fingers to avoid pinching.
- The scooter may only be used by one person at a time, with a maximum load of 100 kg.
- Only use the scooter if it is in perfect condition. Check for damage and wear before each use. Ensure all connection elements, such as the folding mechanism and handlebar adjustment, are secure and locked properly.
- Always wear appropriate protective equipment, including a helmet, hand/wrist guards, knee pads, and elbow pads.
- Wear sturdy, closed-toe shoes to protect your feet while using the scooter.
- The scooter is not a toy. Do not allow children to use the scooter unsupervised.
- Check and follow local laws and regulations regarding the use of scooters. This may include protective gear requirements and restrictions on where the scooter can be used.
- Use the scooter only on flat, clean, and dry surfaces. Avoid uneven, dirty, or wet surfaces as they can block the wheels and cause falls. Steer clear of steep terrain, water, oil, and potholes.
- Do not use the scooter in darkness or poor visibility conditions.
- Always ride cautiously and be aware of your surroundings. Show consideration for other people.
- Use the scooter only for riding. Do not perform jumps, tricks, or stunts.
- Do not make any unauthorized modifications or repairs to the scooter.
- After prolonged use, the rear brake may become hot. Allow it to cool down before touching to avoid burns.
- Do not expose the scooter to high temperatures and humidity as it can cause

damage.

- Do not use the scooter indoors. Smooth surfaces like laminate, parquet, and tiles can cause the tires to lose grip and skid.
- Keep away from open flames and ensure the scooter is not exposed to extreme environmental conditions.
- Do not use headphones or talk on the phone while riding.
- Follow traffic rules and yield the right-of-way as required.
- Do not ride near stairs or open water.
- Ensure children are supervised while using the scooter, as they may not assess potential dangers adequately.
- **Preventing damage to the product:** Avoid water, oil, potholes, and very rough surfaces.
- Make sure all parts are undamaged. Damaged parts can affect safety and stability.
- Ensure all connection elements and fasteners, such as the folding mechanism and handlebar height adjustment, are intact and secure.
- Do not ride at dawn, dusk, or in poor visibility.
- Self-locking nuts and other self-locking fasteners can lose their effectiveness if loosened and tightened multiple times. Check the steering adjustment for correct alignment and fastening.

1.4 Initial Setup

- **Unpacking:** Remove the contents from the packaging. Discard the cardboard and brown paper used to protect the components during transport.
- **Safety Checks:** Before each ride, perform the following safety checks. Do not ride the scooter if it is not in perfect condition. Replace any worn or broken parts.

<u>Brakes</u>	<ul style="list-style-type: none"> • The rear brake must function perfectly. Ensure it is operating correctly before each use.
<u>Bearings</u>	<ul style="list-style-type: none"> • All bearings must be lubricated, run freely, and have no excessive play, scraping, or rattling. • The wheel bearings should be lubricated annually with lithium grease.
<u>Handlebar</u>	<ul style="list-style-type: none"> • The handlebar must be properly adjusted and tightened, ensuring smooth steering. • It should be correctly aligned with the fork and the direction of travel. • The handlebar clamp bolt must be securely tightened.
<u>Frame and Fork</u>	<ul style="list-style-type: none"> • The frame and fork must not be bent or broken. Inspect them regularly for any signs of damage.
<u>Wheels</u>	<ul style="list-style-type: none"> • Ensure there is no dirt or grease on the rims. • The wheels must be securely attached to the scooter and the axle. • Regularly check the wheel attachment for stability.

- **Accessories:** Inspect all parts before each ride to ensure they are securely fastened and functioning properly.
- **Rider Safety:** The rider must wear a properly fitted helmet and well-fitted, non-loose clothing (protective gear if necessary). Secure any loose items before riding.

2 Delivery Content and Technical Data

2.1 Delivery Content

- 1 x scooter
- 2 x allen key
- 1 x carry strap
- 1 x instructions for use

2.2 Technical data

Maximum weight capacity	Class A -100kg
Tested according to: EN 14619:2019 Class A: Suitable for users with a body weight over 20 kg up to100 kg.	
Dimensions unfolded (L x W x H)	90 x 38.5 x 93cm
Dimensions folded (L x W x H)	73.5x11.5x34 cm
Handlebar height adjustable	79 - 93cm
Weight	Approx.5.2kg
Wheel diameter	Ø 200mm
Bearings	ABEC 7

3 Assembly

Before Assembly, please check the Contents:

Remove the scooter from the packaging. Check if the scooter or any parts of the scooter are damaged. If this is the case, do not use the scooter and contact our customer service.

The item is delivered folded in a transport condition. To make it ready for use, proceed as follows:

Unfolding (Fig.1)

- Release the lower quick-release lever (A).
- Lift the lever (B) and tilt the steering column (C) forward until it clicks into place.
- Tighten the lower quick-release lever to secure the folding mechanism.

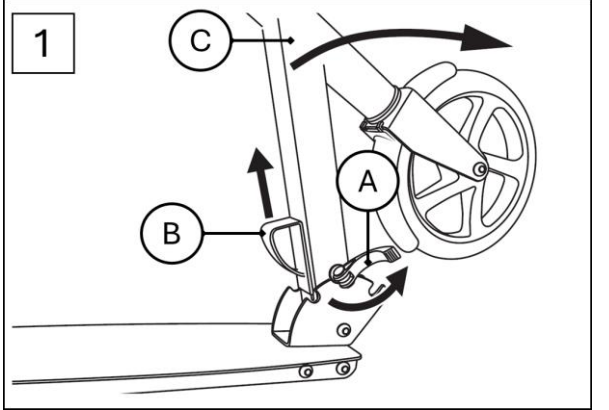

Mounting the grips (Fig. 2)

- Detach the grips (D) from the holder (E).
- Press the locking knobs (G) on the grips and insert the grips into both sides of the T-tube (H) on the steering column. Ensure the locking knobs audibly snap into the designated holes (I).

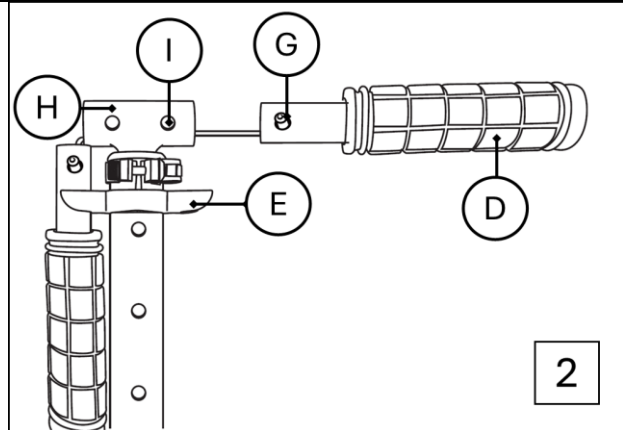

Adjusting the height of the steering column (Fig. 3)

The steering column can be set to four different heights. Make sure the product is used only when the locking knob is firmly engaged in one of the four designated holes and the steering column is secured with the quick-release fastener.

- Open the quick-release lever (J) on the steering column (C).
- Pull the steering column upward until the locking knob (L) clicks into one of the four holes (K).
- Lock the steering column by closing the quick-release lever.

Note: If the quick-release lever does not fit tightly when secured, use the provided Allen key to firmly tighten the knurled screw. Ensure the quick-release lever is properly fastened before use.

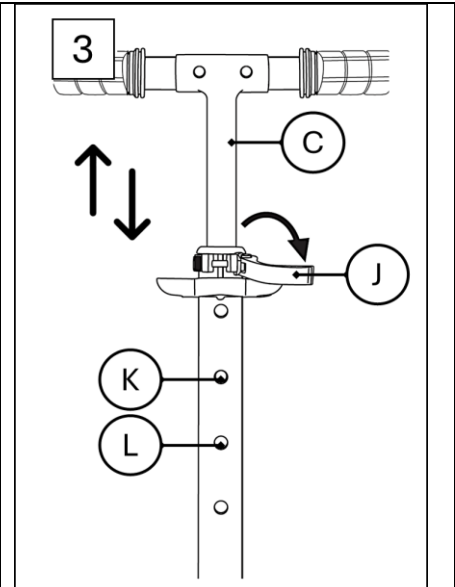

Steering head bearing (Fig. 4)

Upon delivery, the steering head bearing (M) is preset.
If the handlebar develops excessive play or becomes too tight over time, have the steering head bearing adjusted by a specialist retailer or bicycle shop.

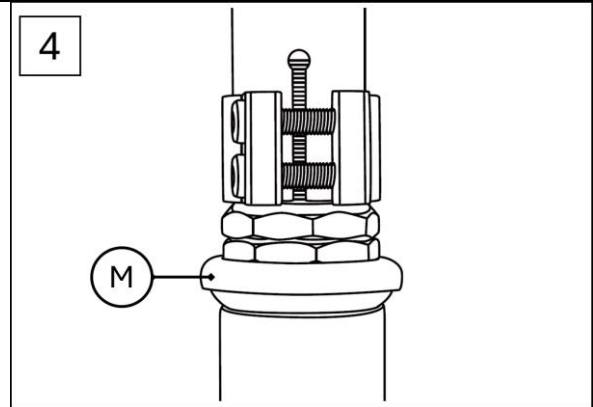

Folding the Scooter for Transport (Fig 2,3,5,6,7)

- Release the quick-release lever (J) on the steering column (C) and press the locking knob (L) (Fig. 3).
- Push the steering column (C) all the way down and tighten the quick-release lever (J) (Fig. 3).
- Press the locking buttons (G) on the handles and pull the grips (D) out of the T-bar (H) (Fig. 2).
- Secure the grips in the holders (E) (Fig. 2).

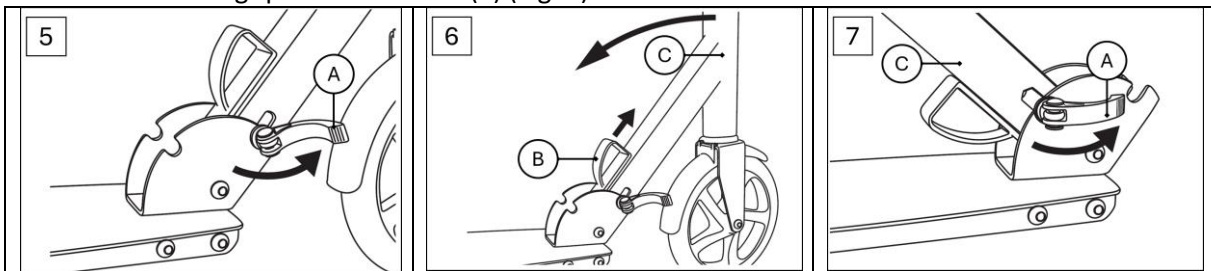

- Loosen the lower quick-release lever (A) (Fig. 5) and pull the lever (B) (Fig. 5) upwards.
- Push the steering column (C) towards the deck until it locks into place (Fig. 6).
- Secure the lower quick-release lever (A) (Fig. 7).

Riding, braking, parking (Fig. 8)

Before Use: Ensure the kickstand (P) is fully retracted.

Riding: Place one foot on the deck (N) and propel yourself forward by pushing off regularly with the other foot.

Braking: To brake, step on the brake plate (O).

Parking: Extend the kickstand (P) to park the scooter. **Ensure the scooter is only parked on level surfaces.**

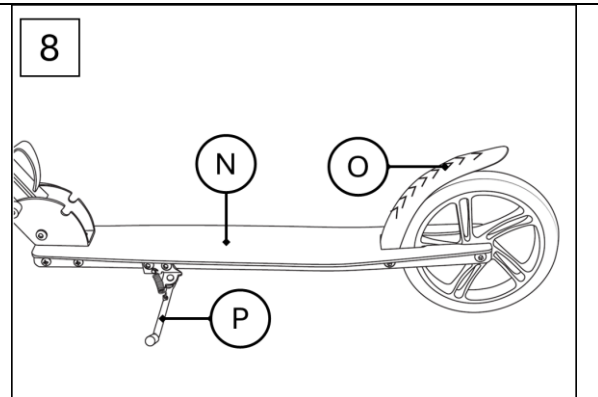

4 Maintenance, Cleaning and Storage

4.1 Maintenance

- Before and after use, check the scooter for damage and wear.
- Self-locking nuts and other fasteners may lose their effectiveness after repeated use. Regularly check and tighten them as needed.
- Pay particular attention to the tightness of screw connections and tighten screws if necessary.
- If the scooter shows any signs of damage, do not use it. Do not make any repairs or structural changes to the scooter.
- Regular maintenance increases the safety of the scooter. Failing to maintain the scooter can lead to malfunction of critical parts, resulting in severe injury or death. Proper maintenance is crucial for performance and safe operation.
- The recommended intervals and necessity for lubrication and maintenance may vary depending on the conditions the scooter is exposed to. Inspect the scooter before each use and perform necessary maintenance tasks.

Replacing the Wheels (Fig. 9)

Important! Using wheels with a different diameter can alter the riding characteristics and may pose a safety risk. Only use wheels that can be easily installed and never install wheels larger than the original ones on the scooter. Wheels wear down over time due to various factors such as the ground surface, user size and weight, weather conditions, and the material and hardness of the wheels. Therefore, they need to be replaced periodically.

- Use two size 5 socket head wrenches to loosen the axle bolts (Q).
- Remove the axle bolts and take off the worn wheel.
- Install the new wheel (R) and secure it with the axle bolts.

After Replacing:

- If the wheel grinds against the side after replacement, do not use the scooter.
- Ensure all screws are tight after the first few minutes of riding and check that nothing has come loose or detached.
- Retighten the wheel to ensure it operates smoothly and that the bearings are quiet.

Replacing the Ball Bearings (Fig. 10)

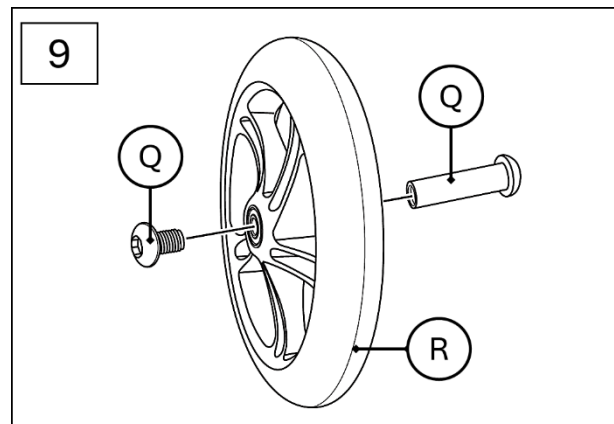

- Follow the instructions in the "Replacing the Wheels" section to remove the wheel (R).
- Use a socket head wrench to carefully pry out the bearing (T).
- Take out the spacer (S) from the wheel and flip the wheel over.
- Use the socket head wrench to pry out the other bearing.
- Press a new bearing into place. Flip the wheel over, insert the spacer, and then press in the second new bearing.
- Reattach the wheel by following the steps in the "Replacing the Wheels" section.

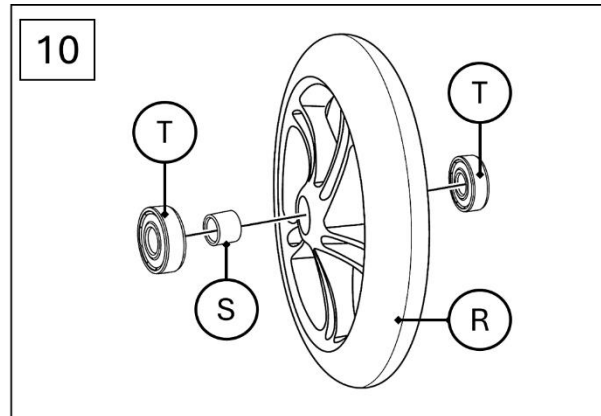

4.2 Cleaning and Storage

- After using the scooter, we recommend thorough cleaning and drying.
- Clean the scooter with a damp cloth. Do not use solvent-based or harsh cleaning agents.
- Remove small stones or other objects that may be stuck to the rollers.
- Dry wet or damp ball bearings with a clean cloth. Grease the bearings with suitable bearing grease from the outside to prevent rust formation.
- Allow the scooter to dry completely after cleaning.
- Always store the scooter in a dry and frost-free location.

5 Environmentally friendly disposal

Warning Danger of suffocation! Packaging material is dangerous for children. Never let children play with packaging material.

5.1 Disposal and packaging

- The packaging of your unit consists of materials that are necessary to guarantee effective protection during transport. These materials are fully recyclable and therefore reduce the environmental impact. Dispose of the packaging in a bin for recyclable materials.

5.2 Disposal of old equipment

- Old appliances must be disposed of in accordance with the guidelines and regulations of the local waste disposal authority. Check with your local administration for the address of the nearest recycling centre and deliver your appliance there.

Our customer service number: Tel. +49 931 90 80 3000

E-Mail: info@arebos.de

Office address: Canbolat Vertriebs GmbH • Gneisenaustraße 10-11 • 97074 Würzburg

Return address can be found in the imprint: <https://www.arebos.de/impressum/>

Declaration of Conformity

We, the

Canbolat Vertriebs GmbH, Gneisenaustraße 10-11, 97074 Würzburg, Germany,

hereby declare that the equipment described below, by virtue of its design and construction and in the versions placed on the market by us, complies with the relevant essential health and safety requirements of the EU directives.

Product name: AREBOS Scooter

Model number: AR-HE-TRP/R/B/G

Article number: 4252023125215; 4252023125222; 4252023125239; 4252023125246

Should the appliance be modified without our consent, this declaration of conformity will lose its validity.

EU Standard:

EN 14619:2019

Date/Signature Manufacturer/Place:

Würzburg, July 15, 2024



Signature:

Dipl.-Inform. (Univ.) Korhan Canbolat, Managing Director

Representative of these instructions for use/technical data:

Dipl.-Inform. (Univ.) Korhan Canbolat, Managing Director

Office address:

Canbolat Vertriebs GmbH

Gneisenaustraße 10-11

D-97074 Würzburg

Return address can be found in the imprint: <https://www.arebos.de/impressum/>

VAT identification number: DE 263752326

Court of the Commercial Register is Würzburg, HRB 10082

WEEE Reg.-No. DE 61617071