

# AREBOS

## Refrigerator

AR-HE-KK30/40/50A



Please follow all security measures in this user's manual to ensure a secure use.



Thank you for trusting in AREBOS.



# Table of Contents

<b>1. Security instructions.....</b>	<b>3</b>
1.1 Explanation of the symbols.....	3
1.2 General security instructions.....	4
1.3 Special security instructions for the device.....	6
1.4 Other important instructions for the device.....	6
<b>2. Product Overview.....</b>	<b>7</b>
2.1 Part Names.....	7
2.2 Size Description (Unit: mm).....	7
2.3 Control Panel.....	8
<b>3. Functions and Operation.....</b>	<b>10</b>
3.1 Initial Use.....	10
3.2 Power Supply.....	10
3.3 Display Screen Initialization.....	10
3.4 Power ON/OFF.....	10
3.5 Temperature Setting.....	10
3.6 Cooling Mode.....	10
3.7 Temperature Unit Setting.....	10
3.8 Reset.....	11
3.9 Battery Protection Mode.....	11
3.10 Recommended temperature for common food.....	11
3.11 Reverse Door Opening Direction.....	12
<b>4. Technical data.....</b>	<b>12</b>
<b>5. Cleaning and care.....</b>	<b>14</b>
5.1 Cleaning.....	14
5.2 Storage.....	14
5.3 Maintenance.....	14
<b>6. Troubleshooting.....</b>	<b>15</b>
<b>7. Environmentally friendly disposal.....</b>	<b>17</b>
7.1 Disposal and packaging.....	17
7.2 Disposal of waste equipment.....	17
<b>EU Declaration of Conformity.....</b>	<b>18</b>

Thank you for purchasing our product. Please read the operating instructions carefully before using the product for the first time. If you give the product to a third party, this manual must be handed over with it. Keep the instruction manual for future reference. The drawings in this manual may not match the physical objects. Please refer to the physical objects.

## 1. Security instructions

### 1.1 Explanation of the symbols



By means of a CE marking, it can be recognized that a product complies with the legal requirements of European legal standards and therefore may be traded within the European Community.



Warning! Read the safety instructions carefully. The Failure to follow the safety precautions can result in serious injury or damage. Keep the operating instructions in a safe place.



Protective insulated housing (protection class II)!



Warning: Risk of fire / flammable materials



This product must **not** be disposed of with household waste!

## 1.2 General security instructions

- **WARNING:** Read all safety warnings and all instructions. Failure to follow the warnings and instructions may result in electric shock, fire and/or serious injury.
- Before installation, check that all accessories are fully present and undamaged. If this is not the case, please contact our customer service.
- Keep these instructions in a safe place for future reference.
- This appliance is not intended for use by persons (including children) with reduced physical, sensory or mental capabilities, or lack of experience and knowledge, unless they have been given supervision or instruction concerning use of the appliance by a person responsible for their safety.
- This device can only be used by children from 8 years of age and persons with limited physical, sensory or mental performance or lack of experience and knowledge if they are supervised during use or receive instruction on the safe use of the device and the associated dangers and understood them. Children must not play with the device. Cleaning and maintenance must not be carried out by children.
- **Danger!** Keep children away from packaging material. There is choking hazard.
- Cleaning and user maintenance must not be carried out by children without supervision.
- Children aged 3 to 8 years are allowed to load and unload cooling devices.
- In this appliance, do not store any explosive substances, such as aerosol containers with flammable propellant.
- **CAUTIONS! In order to avoid hazards and to comply with safety regulations, repairs may only be carried out by qualified personnel. Incorrect repair may cause danger.**
- If the lamp or the supply cord is damaged, it must be replaced by the manufacturer or qualified personnel in order to avoid a hazard.
- The installation of DC power in the boat must be handled by qualified electricians.
- The device can be connected to more than one energy source.
- Do not operate the cooling device if it is visibly damaged.
- Before commissioning, check the entire device including the connecting cable and any accessories for defects and damage that could impair the functional safety of the device. If the device e.g. has fallen to the ground or has been pulled on the connecting cable, there may be damage that is not visible from the outside. In these cases, do not operate the device.
- Both connecting cables must not be connected at the same time.
- Disconnect the cooling device from the power supply before each cleaning and maintenance and after every use
- Do not pull the power plug out of the socket by the connecting cable, but grasp the power plug.
- If the device is operated incorrectly or used for other purposes, no liability can be accepted for any damage that may occur.
- Before starting the cooling device, ensure that the power supply line and the plug are dry.
- Check the voltage specification on the type plate corresponds to that of the energy supply. The appliance is only to be used with the power supply unit provided with the appliance.
- **Warning: When setting up the device, make sure that the power cord is not**

**trapped or damaged.**

- **WARNING: Do not locate multiple portable socket outlets or portable power supplies at the rear of the appliance.**
- Do not use electrical appliances inside the food storage compartments of the appliance, unless they are of the type recommended by the manufacturer.
- Do not place the cooling device near naked flames or other heat sources (heaters, direct sunlight, gas ovens etc.).
- Before cleaning, pull the mains plug and let the device cool if necessary.
- To protect yourself against electric shock, do not immerse the cable, plug, or device in water or other liquids.
- Protect the device and cables from moisture, direct sunlight and shocks.
- The device must not be exposed to rain. Do not let liquids run into the fan openings or fill into the cooler.
- Do not fill the inner container with ice or fluids.
- Keep the appliance stable on the ground or in the car; Do not drain upside down.
- **Risk of overheating! Do not place the cooling device in closed areas with none or minimal air flow.**
- Keep the ventilation area free of obstacles that could limit the air flow to the cooling components.
- Make sure that the ventilation openings are not covered.
- Do not use mechanical devices or other means to accelerate the defrost process, other than those recommended by the manufacturer.
- Do not damage the refrigerant circuit.

### 1.3 Special security instructions for the device

- When selling, handing over or handing in for recycling, the blowing agent cyclopentane in the insulation of the cooling device must be mentioned.
- Once unpacked, before first installation or operation, keep this device upright on a level surface for min. 6 hours.
- Make sure that the appliance stays horizontally when it is running. The tilt angle must be less than 5° for long time running and less than 45° for short time running.

### 1.4 Other important instructions for the device

#### Intended Use:

- The cooling device is suitable for camping use or intended to be used in household and similar applications such as:
- Staff kitchen areas in shops, offices and other working environments;
- Farm houses and by clients in hotels, motels and other residential environments;
- Bed and breakfast type environments;
- Catering and similar non-retail applications.

#### To avoid food contamination, follow these instructions:

- If you open the door for a long period of time, the temperature inside the device will increase significantly.
- Food may only be stored in its original packaging or in suitable containers.
- Check if the cooling capacity of the appliance is suitable for storing the food or medicine.
- Regularly clean surfaces that come into contact with food and drainage systems that are accessible.

#### If the cooling device has not been used for a long time, please

- switch it off
- defrost the appliance
- clean and dry it
- open the door to prevent mold from forming inside.

## 2. Product Overview

### 2.1 Part Names

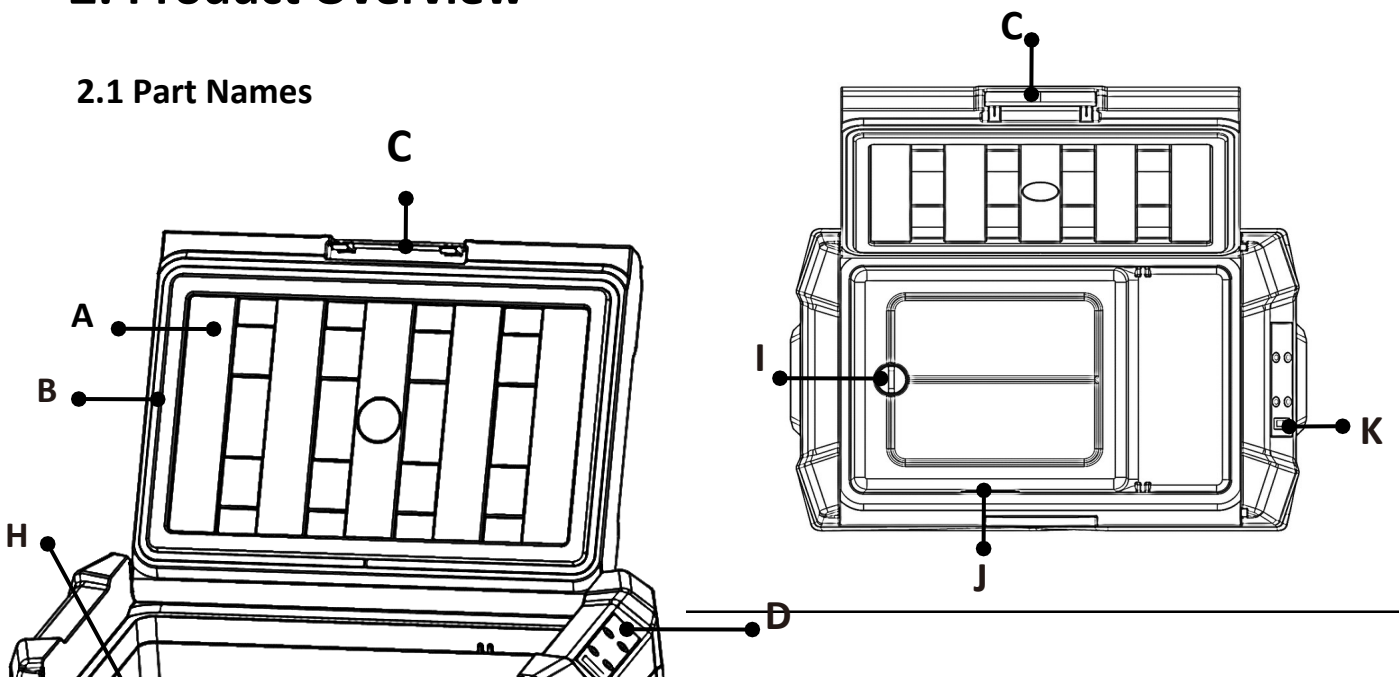

## 2.2 Size Description (Unit: mm)

- **AR-HE-KK30A**

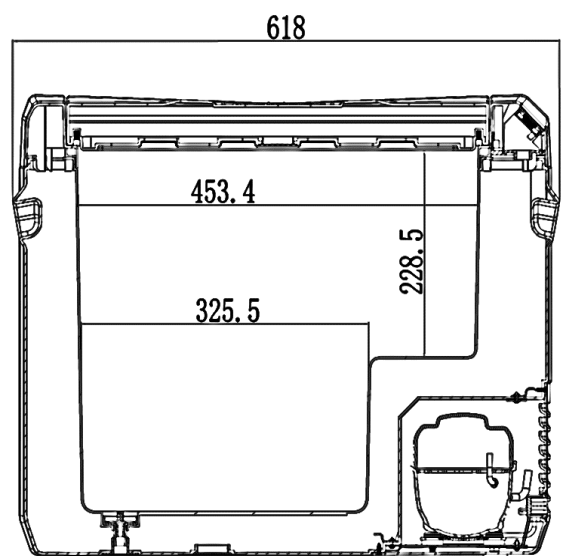
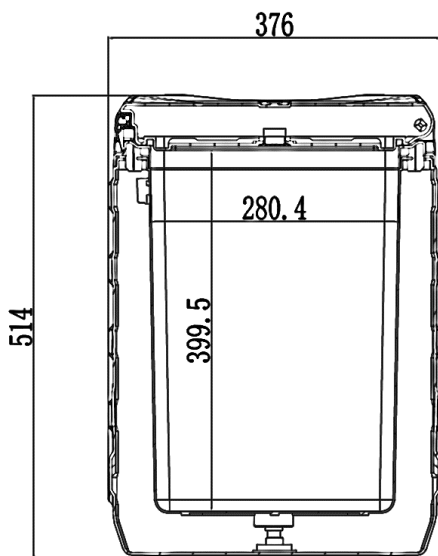
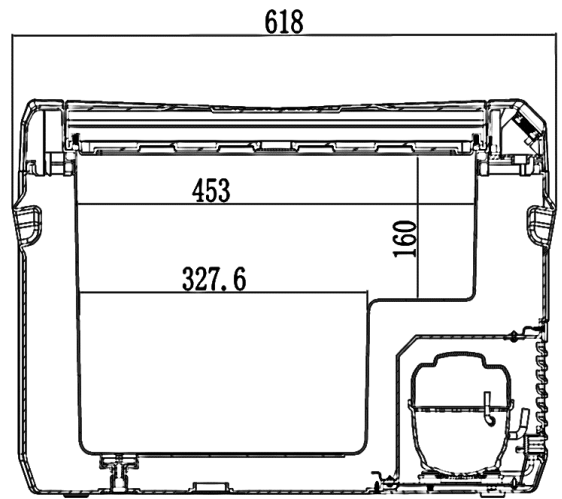
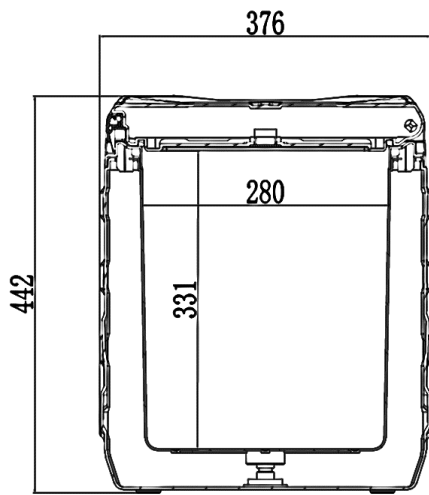
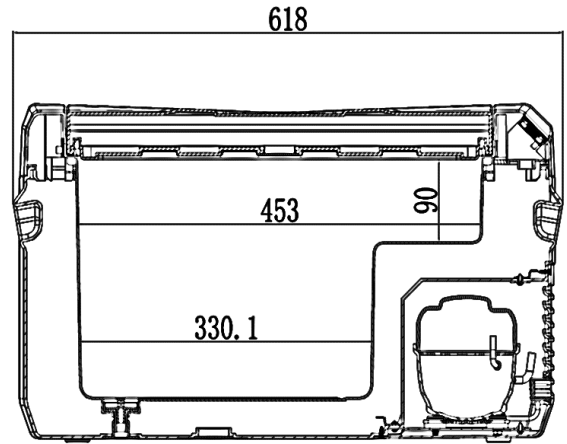
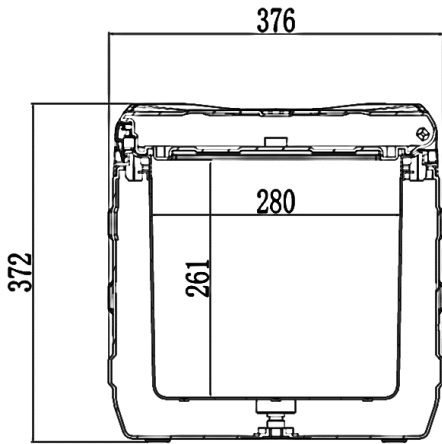

## 2.3 Control Panel

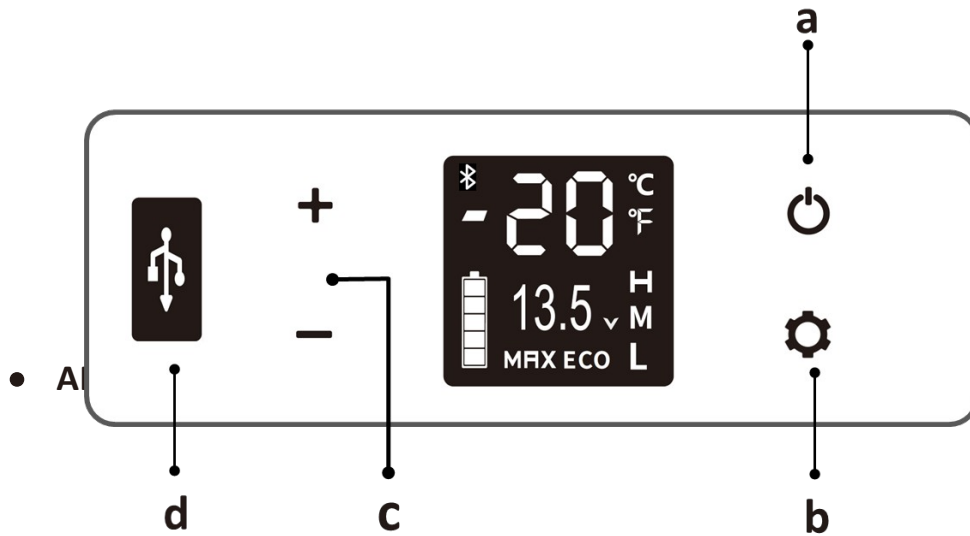

Designation	Description
a	ON/OFF
b	SET Button
c	Temperature Setting
• <b>AR-HE-KK50A</b>	
d	USB 5V/1A

Designation	Description
e	Current Temperature
f	Temperature Unit
g	Current Voltage
h	Current Battery (for reference)
i	MAX ( Fast cooling )
j	ECO ( Energy-saving)
k	(H.M.L) Battery Protection Mode
l	bluetooth

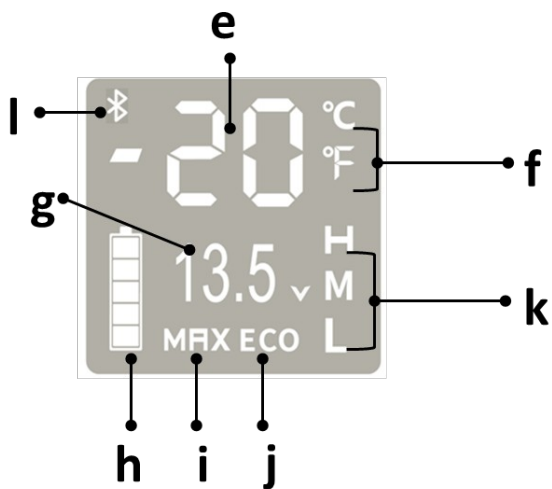



## 3. Functions and Operation

### 3.1 Initial Use

- Take the device and accessories out of the box. Remove the stickers, protective film or plastic parts from the device.
- Wipe all removable parts with a damp cloth before using the device for the first time. Never use abrasives.
- **Important note: After unpacking for the first time, leave the freezer standing for at least 6 hours before turning it on. Always keep the freezer horizontal.**
- The cooler can not only be used to cool food and drinks in the room, but also be taken as the small portable refrigerator to store fresh food and drinks in the car.

### 3.2 Power Supply

DC 12V/24V or AC 100-240V power (using dedicated adapter).



### 3.3 Display Screen Initialization

When the fridge is powered on, the buzzer will make a long beep, and the display will be on for two seconds then enter the normal operation.

### 3.4 Power ON/OFF

- Press “” to switch ON/OFF.
- **AC Power mode:** Plug the AC cord into the cooler and to a power supply, then the cooler is ready to work. To turn it off, press ON/OFF button and remove power cord.
- **DC Power Mode:** Plug the cigarette lighter adaptor into the cooler and to the power supply in the car to turn it on. To turn it off, press ON/OFF button and remove power cord.

### 3.5 Temperature Setting





- Press “” or “” to set up desired temperature. The setting will be saved automatically after stopping operating for 3 seconds.
- Note: the temperature displayed is the current temperature of the compartment, it will take a while to reach the set temperature.
- Note: Temperature setting range: -20~20°C ( -4~68°F )

### 3.6 Cooling Mode

under running state, press  to switch MAX (Fast cooling, Eco) or ECO(Energy saving) mode.



**Note: Factory setting is MAX.**

### 3.7 Temperature Unit Setting

switch off the fridge, long press “” for 3 seconds until displays E1, and switch to E5 by pressing “” again, then press “” or “” to switch Celsius or Fahrenheit.



Note: Factory setting is °C.

### 3.8 Reset

Switch off the fridge. Long press “” for 3 seconds until it displays E1, under E1 mode, long press “” at the same time for seconds to reset the settings.

### 3.9 Battery Protection Mode

- In order to prevent the cooler from running down the car battery, the cooler is equipped with BATTERY PROTECTION MODE.
- **To select BATTERY PROTECTION MODE:**

When the cooler is running, please press the “” button for 3 seconds until screen flashes, then press “” button again to select protection mode H(high), M(medium), L(low).

**Note: Factory setting is H3.**

- **Voltage Reference:**

INPUT	DC 12V		DC 24V	
	CUT OUT	CUT IN	CUT OUT	CUT IN
L	8.5V	10.9V	21.3V	22.7V
M	10.1V	11.4V	22.3V	23.7V
H	11.1V	12.4V	24.3V	25.7V

Note: Due to the different output voltages of different vehicle power supplies, you can lower the battery protection setting by one level when voltage protection is displayed (when the display shows “F1”) (H set to M or L).







We do not recommend leaving the freezer running with the motor off.

- If you need to leave the freezer running with the engine off, set the protection level to H.
- If the freezer runs for too long without the engine turned on, the vehicle may not start.

Note: The voltage is theoretical value. There may be a deviation in different sceneries.

- It is recommended to select protection mode H when connected to car power.
- M or L should be set when it is connected to a portable battery or other back-up battery.

### 3.10 Recommended temperature for common food

						
Drinks	Fruits	Vegetable	Delicatessen	Wine	Ice cream	Meat
5°C/41°F	5~8°C/41~46°F	3~10°C/37~50°F	4°C/39°F	10°C/50°F	-10°C/14°F	-18°C/0°F

### 3.11 Reverse Door Opening Direction

- The lid has two opening directions and can be taken off at an angle of 20°.
- When installing it back, align the door shaft with the compartment hole and then insert it.

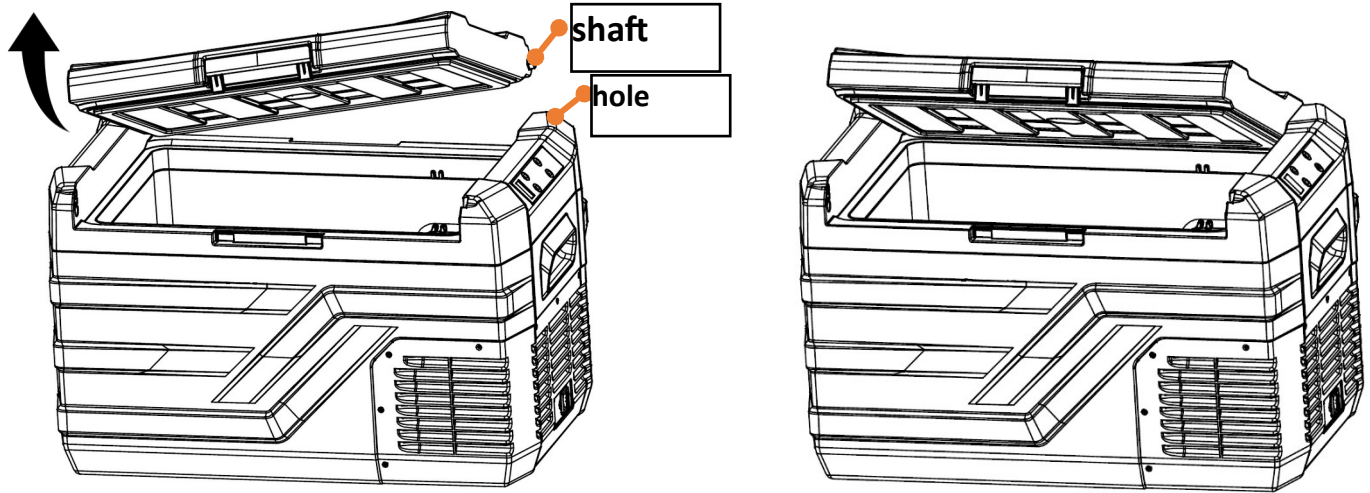

## 4. Technical data

Model	AR-HE-KK30A	AR-HE-KK40A	AR-HE-KK50A
EAN	4252023117739	4252023117746	4252023117753
Volume	26L	35L	43L
Rated Voltage	DC12V /24V AC100-240V 50-60HZ		
Rated Power	60W		
Climate Class	T/ST/N		
Insulation blowing gas	C5H10		
Refrigerant	R1234yf		
Refrigerant quantity	40g		
Protection Class	II		
Rated Power	60W		
Temperature Setting range	-20~20°C(-4~68°F)		
Dimensions(L*W*H)	618*376*372mm	618*376*442mm	618*376*514mm
Net Weight	11.6kg	12.7kg	13kg

**Important note:** After unpacking for the first time, leave the freezer standing for at least 6 hours before turning it on. Always keep the freezer horizontal.

## 5. Cleaning and care

### 5.1 Cleaning

- Before cleaning, pull out the mains plug and let the device cool down.
- Do not immerse the cooler in water and wash the cooler directly.
- The interior and exterior of the device should be cleaned at least monthly for hygienic reasons; Clean the inside and outside of the case with mild detergent.
- Wipe the lid with a slightly damp cloth and then dry it.
- Clean the container with a damp cloth, if necessary, with a little detergent. Then dry the container.
- Make sure that the air inlet and outlet vents on the device are free of any dust and dirt.
- Never use caustic cleaning agents, steel wool and / or scouring pads as these can damage the device.
- Do not use any abrasive cleaning agents to clean the cooler as these agents may cause damages to the product.

### 5.2 Storage

If the device will not be in use for a long time, please follow the instruction:

- Switch off and unplug the device.
- Take out all the items stored in the device.
- Wipe off excess water with a soft cloth.
- Store the device in a cool and dry place.
- Leave the lid slightly open to prevent odors from forming.
- Recommended storage environment: ambient temperature: 25°C, ambient humidity: ≤ 75%.

### 5.3 Maintenance

Frost will reduce the cooling capacity (Humidity form frost in the interior of the cooling device or on the evaporator.). It is suggested to defrost in time:

- Switch off and unplug the device first to avoid electric shock.
- Turn off and unplug the device
- Empty storage room of the device.
- Leave the lid open.
- Wipe off the defrosted water with soft cloth.

**Warning! Do not use hard or sharp tools to remove ice or any objects which have frozen in place.**

## 6. Troubleshooting

Issues	Cause/Suggestions
Refrigerator does not work	<ul style="list-style-type: none"> <li>• Check if the ON/OFF switch is on.</li> <li>• Check if the plug and socket are connected well.</li> <li>• Check if the fuse has been burnt.</li> <li>• Check if the power supply is malfunctioned.</li> <li>• Switch on/off the fridge frequently may cause start delay of the compressor. There is a three-minute compressor delay safety period after the freezer is turned on. Check if the freezer turns on after three minutes.</li> </ul>
Cooler storage box is abnormally warm	<ul style="list-style-type: none"> <li>• The cooler lid is opened frequently.</li> <li>• A large amount of warm or hot food was stored recently.</li> <li>• The refrigerator has been disconnected from power for a long time.</li> </ul>
Food/object is frozen in the cooler or excessive freezing in the refrigerator	<ul style="list-style-type: none"> <li>• The temperature is set too low.</li> <li>• Make sure the door is closed and the seal is intact is.</li> <li>• Make sure the inside of the freezer is dry before use.</li> </ul>
There is "water flow" noise from the refrigerator inside	<ul style="list-style-type: none"> <li>• It's normal and from the compressor inside. This is the normal sound of flowing refrigerant.</li> </ul>
Water drops around the refrigerator casing or cooler lid sealing	<ul style="list-style-type: none"> <li>• It's a normal phenomenon.</li> <li>• the moisture will condense to water when it touches a cold surface of the refrigerator.</li> <li>• This condensation can be wiped off with a towel.</li> </ul>
The compressor starts noisily.	<ul style="list-style-type: none"> <li>• It's a normal phenomenon.</li> <li>• When the compressor initially starts, the engine is normally running at a high speed. This produces a loud noise, but this noise decreases after the speed stabilizes.</li> </ul>
Inaccurate temperature displayed.	<ul style="list-style-type: none"> <li>• If objects placed inside are too hot, the internal temperature will be uneven while the temperature stabilizes.</li> <li>• Frequently opening and closing the freezer door causes variable airflow, resulting in an unstable internal temperature.</li> <li>• Make sure the unit of your thermometer matches the unit of the freezer display.</li> </ul>

Error Code	Cause/Suggestions
Code F1 displayed	<ul style="list-style-type: none"> <li>• Possible cause: low voltage protection</li> <li>• Adjust the battery protection mode from High to Medium or from Medium to Low.</li> </ul>
Code F2 displayed	<ul style="list-style-type: none"> <li>• Possible cause: condenser fan is overloaded.</li> <li>• Turn off the freezer and cut the power off for 30 minutes &amp; re-start.</li> <li>• If the code occurs again, contact manufacturer for service.</li> </ul>
Code F3 displayed	<ul style="list-style-type: none"> <li>• Possible cause: the compressor starts too frequently.</li> <li>• Turn off the freezer and cut the power off for 30 minutes &amp; re-start.</li> <li>• If the code shows again, contact manufacturer for service.</li> </ul>
Code F4 displayed	<ul style="list-style-type: none"> <li>• Possible cause: compressor not kicking in. The compressor speed is too low or the load is too high.</li> <li>• Turn off the freezer and cut the power off for 30 minutes &amp; re-start.</li> <li>• If the code shows again, contact manufacturer for service.</li> </ul>
Code F5 displayed	<ul style="list-style-type: none"> <li>• Possible cause: overheating of the compressor &amp; electronics.</li> <li>• Turn off the freezer and leave it unplugged in a well-ventilated place for 30 minutes and then restart.</li> <li>• If the code shows again, contact manufacturer for service.</li> </ul>
Code F6 displayed	<ul style="list-style-type: none"> <li>• Possible cause: no parameter can be detected by the controller.</li> <li>• Cut the power off for 5 minutes &amp; re-start.</li> <li>• If the code shows again, contact manufacturer for service.</li> </ul>
Code F7 or F8 displayed	<ul style="list-style-type: none"> <li>• Possible cause: temperature sensor is faulty.</li> <li>• Please check the temperature sensor terminal or contact manufacturer for service.</li> </ul>

## 7. Environmentally friendly disposal

**⚠ Warning! from the risk of suffocation!** Packaging material is dangerous for children. Never let children play with packaging material.

### 7.1 Disposal and packaging

- The packaging of your device is made of materials necessary to guarantee effective protection during transport. These materials are fully recyclable and thus reduce the environmental impact. Dispose of the packaging in a bin for recyclable materials.

### 7.2 Disposal of waste equipment

- Waste equipment must be disposed of in accordance with the guidelines and regulations of local waste disposal. Contact your local administration via the address of the nearest recycling centre and deliver your device there.



The symbol of the crossed-out waste bin on an OLD electrical or electronic equipment states that it must not be disposed of in household waste at the end of its service life. Collection points for WASTE electrical and electronic equipment are available in your area for free returns. You can obtain the addresses from your city or local government. You can inform yourself on our website [www.arebos.de](http://www.arebos.de) about other return options created by us.

The separate collection of WEEE is intended to prevent reuse, recycling or other forms of recovery of WEEE, as well as the negative consequences of disposal on the environment and human health.

**Our customer service number: Tel. + 49 931 452 327 00**

**e-mail: [info@arebos.de](mailto:info@arebos.de)**

Office address: Canbolat Vertriebs GmbH • Gneisenaustraße 10-11 • 97074 Würzburg

**Return address** can be found in the imprint: <https://www.arebos.de/impressum/>

Sales tax identification number: DE 263752326

Court of commercial registration is Würzburg, HRB 10082

WEEE-Reg. No. DE 61617071



## EU Declaration of Conformity



We, the **Canbolat Vertriebsgesellschaft mbH**  
Gneisenaustrasse 10-11  
97074 Würzburg, Germany

declare, under sole responsibility, that the following product:

Brand **AREBOS**  
Product Refrigerator  
Product Model AR-HE-KK30A/ AR-HE-KK40A/ AR-HE-KK50A  
Article 4252023117739 / 4252023117746 / 4252023117753

has been developed, designed 2014/35/EU  
and manufactured in accordance 2014/30/EU  
with the requirements of 2011/65/EU  
**European directives:** 2009/125/EC

The subject matter of the declaration described above is in accordance with the relevant harmonisation legislation of the European Union.

The assessment shall be based on the following **harmonised standards** applied:

EN 60335-1:2012+A11:2014+A13:2017+A1:2019+A14:2019+A2:2019  
EN 60335-2-24:2010+A1:2019+A2:2019+A11:2020  
EN 62233:2008  
EN IEC 55014-1:2021  
EN IEC55014-2:2021  
EN IEC61000-3-2:2019+A1  
EN 61000-3-3:2013+A1  
CISPR14-1:2020 CISPR 14-2:2020  
IEC61000-3-2:2018+A1:2020  
IEC61000-3-3:2013+A1:2017+A2:2021  
EN 62552-1:2020 + EN 62552-2:2020 + EN 62552-3:2020  
EN 60704-2-14:2013+A11:2015+A1:2019  
EN IEC 60704-1:2021

Other applied technical standards and specifications: (EU) 2015/863 (EU)No. 2019/2016  
(EC) No. 1907/2006 (EU)No. 2019/2019  
(EC) No 1935/2004 (EU)No. 2021/340  
(EU) 2017/1369 (EU)No. 2021/341

Place and date of issue: Würzburg, 24/10/2023

Signature:

Dipl.-Inform. (Univ.) Korhan Canbolat, Managing Director

If the device is modified without our consent, this declaration of conformity loses its validity.

# AREBOS

## Fridge Application Instructions

AR-HE-KK30/40/50A

AR-HE-KKR30/40/50A



Please follow all security measures in this user's manual to ensure a secure use.

Thank you for trusting in AREBOS.

**STEP 1 :**

Download the "CAR FRIDGE FREEZER" Application:



IOS



Android

- Scan the QR code on the above or search for the "CAR FRIDGE FREEZER" APP in the APP Store (for Apple devices) or Google Store (for Android devices).

**STEP 2 :**

- Turn on the Bluetooth function on your smart device.
- start the APP and click "Start Scanning".
- Choose the device "WT-0001"

**STEP 3 :**

- Click fridge icon for Bluetooth pairing (the APP will prompt you to pair the fridge by pressing the SET button (⚙️) on the fridge's control panel when connecting the fridge for the first time).
- After pairing, the APP will switch to the main interface allowing you to control the fridge.

**APP Control**

- ① MENU
- ② Current temperature
- ③ Current voltage
- ④ Target temperature
- ⑤ Temperature control
- ⑥ SET
- ⑦ ON/OFF
- ⑧ Current battery status
- ⑨ Temperature control
- ⑩ ECO(Energy-saving) / MAX(Fast-cooling)
- ⑪ Lock / Unlock
- ⑫ Temperature Unit: Celsius / Fahrenheit
- ⑬ Unpairing the device and return to search
- ⑭ Battery protection mode: High/Medium/Low

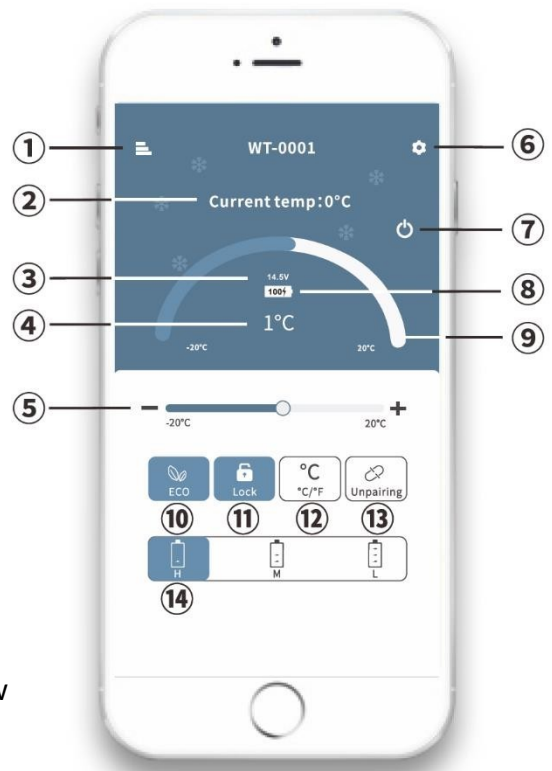

**Note:**

Click the lock icon  on the APP to lock or unlock the control panel on the fridge.

**If under "locked" status, the fridge can only be controlled by the APP.**