

AREBOS

Sand Filter System

AR-HE-SAS350FS, AR-HE-SAB350FS, AR-HE-SAG350FS



Please follow all security measures in this user's manual to ensure a secure use.



Thank you for trusting in AREBOS.



Table of Contents

1. Safety Instructions	3
1.1 Explanation of the symbols	3
1.2 General Safety Instructions	4
1.3 Safety Instructions for electrical devices.....	4
1.4 Functional principle of the sand filtration system.....	5
2. Instruction before Installation.....	5
2.1 Placement.....	5
2.2 Further notes.....	5
3. Technical Data	6
4. Part lists.....	6
5. Assembly	7
6. Filter Function	14
6.1 Connection of the Filter System	14
6.2 Warnings.....	15
7. Use	16
7.1 Before use.....	16
7.2 Priming	16
7.3 During use.....	16
7.4 Functions	16
8. Troubleshooting	17
9. Maintenance	18
9.1 Cleaning	18
9.2 Warnings.....	18
9.3 To be checked regularly	18
10. Environmentally friendly disposal	19
10.1 Disposal and packaging	19
10.2 Disposal of old equipment	19
EU Declaration of Conformity	20

Thank you for purchasing our product. Please read the operating instructions carefully before using the product for the first time. If you give the product to a third party, this manual must be handed over with it. Keep the instruction manual for future reference. The drawings in this manual may not match the physical objects. Please refer to the physical objects.

1. Safety Instructions

1.1 Explanation of the symbols



This product **must not** be disposed of with household waste!



By means of a CE marking, it can be recognized that a product complies with the legal requirements of European legal standards and therefore may be traded within the European Community.

RoHS

Restriction of the use of certain hazardous substances in the area of heavy metals, brominated flame retardants and plasticisers to protect human health and the environment



This product has been tested and certified by TÜV Rheinland. The symbol "GS" stands for tested safety. Products marked with this symbol comply with the requirements of the German Product Safety Act (ProdSG).



Warning of electrical voltage!



Warning! Read the safety instructions carefully. Failure to follow the safety precautions could result in serious injury or damage. Keep the operating instructions in a safe place.

1.2 General Safety Instructions

- The sand filter can be used with a temperature > than 0°C and < than 40°C. You should never operate the filter outside of these temperatures, otherwise damage may occur.
- Ensure that the filter is installed correctly.
- You should read this manual carefully before installation to avoid damage to the product or injury.
- Safety is only guaranteed if the product has been installed properly.
- Do not let children touch the product.
- Escaping fumes or chemicals can weaken the pool. Corrosion can cause filters and other equipment to fail, resulting in serious injury or property damage. Do not store chemicals for the pool near the equipment.
- Replacement of parts should only be performed by qualified personnel.
- The products mentioned in this manual are specifically designed to pre-filter and divert water in pools and fun.
- They are designed to operate with clean water at a temperature not exceeding 40 degrees Celsius.
- Installation should be carried out in accordance with the safety instructions for pools, in particular the HD 384.7.702 standard, and the specific instructions for each installation.
- The mandatory accident prevention regulations should be carefully followed.
- Modifications to the pump require the prior consent of the manufacturer. Original spare parts and accessories authorized by the manufacturer guarantee a high level of safety. The manufacturer of the pump accepts no liability for damage and injury caused by unauthorized spare parts and accessories.
- During operation some parts of the pump are under dangerous electrical voltage. Work on each pump or on the equipment connected to it may only be carried out after it has been disconnected from the mains supply and the starting device has been disconnected.
- The user should ensure that assembly and maintenance work is carried out by qualified, authorized personnel and that these persons have first read the maintenance and installation instructions carefully.
- Under no circumstances should the limits given in the technical table be exceeded.
- If the power cord is damaged, it must be replaced by the manufacturer or its service representative or a similarly qualified person to avoid any risk.
- The pump must not be used when there are people in the water.
- The pump must be supplied via a residual current circuit breaker with a rated residual current of no more than 30 mA.
- Children should be closely supervised to prevent them from playing with the pump.
- This appliance is not intended for use by persons (including children) with reduced physical, mental or cognitive abilities, or lack of experience and knowledge, unless they have been given supervision or instruction concerning use of the appliance by a person responsible for their safety.
- Children should be supervised to ensure that they do not play with the appliance.
- The pump must be protected from running dry.

1.3 Safety Instructions for electrical devices

- **The electrical installation must be carried out by a certified electrician.**
- Each pump requires a circuit breaker to disconnect the pump from the power supply. The open contact gap of the circuit breaker must be at least 3mm. The pump must be supplied by an isolating transformer or a residual current circuit breaker with a rated residual current of no more than 30 mA.

- Check the nameplate of the pump for the following:
- voltage, current consumption and cycle.
- The power cable, including the ground cable, must be of 245 IEC 66 quality for models. For models with an input power of less than 1 kW, the quality must be 245 IEC57. All installations must comply with local regulations in accordance with the requirements of IEC 364-7-702.
- Check that the information on the nameplate corresponds to the power supply. Consult an electrician to ensure that the wiring is in accordance with local regulations. Each motor requires either a fused circuit breaker or a circuit breaker. The single-phase motor has a built-in thermal overload switch.

1.4 Functional principle of the sand filtration system

The water flowing in from the piping system is automatically directed upwards onto the filter bed by the multi-way valve. While the water is pumped through the filter sand, dirt and deposits are collected and filtered out by the filter bed. The filtered water is led from the bottom of the filter tank through the multi-way valve and back through the piping system.

2. Instruction before Installation

2.1 Placement

- 1.) Place the filter as close to the pool as possible.
- 2.) Make sure that the ground is level so that the filter cannot fall or slip away.
- 3.) Pay attention to the connections when placing the filter.
- 4.) Make sure that the conformity label faces forward for easy identification in case of service difficulties.
- 5.) Place the pump on a stable and ventilated surface. The pump inlet should be at least 30 cm below the water level.
- 6.) The pump must be installed and placed at a considerable distance from the pool or water source to prevent water from the pool or water source from flowing onto the pump.
- 7.) The pump must also be in a position that allows easy access for regular maintenance.
- 8.) Care must also be taken that the pump is installed in a well-ventilated and dry area, free from flooding.

2.2 Further notes

Use the latest technology in the development and manufacture of our pumps. A few simple precautions during installation will ensure years of operation at no extra cost.

- 1.) The suction line of the pump should not be smaller than 40 mm or 5 mm.
- 2.) The suction line should have as few kinks or elbows as possible. There should be no air traps on the suction line.
- 3.) The installation must be on a solid, flat foundation to which the pump is bolted.
- 4.) The electrical cable of the pump must be wired according to the wiring instructions for the correct voltage and current.
- 5.) All (electrical) wiring work must be carried out by approved electricians and installed according

- to local regulations.
- 6.) The motor must be earthed.
 - 7.) The weight of the pipes and fittings must be carried by itself and not by the pump.
 - 8.) The maximum total head of the pump indicated on the pump label should be specified by the installer.
 - 9.) The permissible temperature is >0 degrees Celsius and <40 degrees Celsius. The pump must never be operated outside these temperatures as this may cause damage.

3. Technical Data

Model Description	AR-HE-SAS350FS, AR-HE-SAB350FS, AR-HE-SAG350FS
Flow Rate (Pump)	9.5m ³ /hr
Designated Flow Rate	6.8m ³ /hr
Max. Operating Pressure	3,5 bar
Filtration Area	0,07m ²
Voltage	230 V AC; 50-60Hz
Sand Volume	20 kg
Protection	IPX5
Delivery content	Sand filter pump 1x. filter ball 600g. user manual 1x

4. Part lists

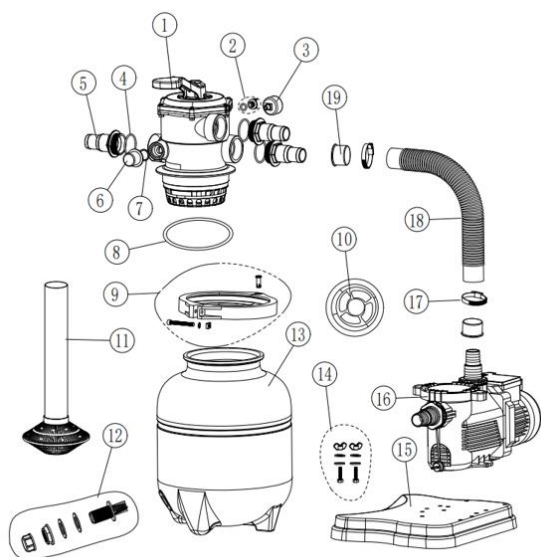

No.	Part name	Material	quantity
1.	7 way valve	-	1
2.	o-ring / cap	Rubber / ABS	1
3.	Pressure gauge	-	1
4.	Valve connector gasket	EPDM	3
5.	Valve connector	PP	3
6.	Transparency cap	PC	1
7.	Gasket	EPDM	1
8.	Valbe big o-ring	Rubber	1
9.	Screw Nuts Gasket Clamp pin Right clamp Left clamp	SUS304 Brass SUS304 PA6 PA6 PA6	1 1 1 1 1 1
10.	Sand funnel	PP	1
11.	Short pipe	PVC / ABS	1
12.	Drain valve	-	1
13.	301 blow moulded tank	HDPE	1
14.	Fitting screws	-	2
15.	Base plate	PP	1
16.	Water pump	-	1
17.	Hose clamp	SUS304	2
18.	Short hose	PE	1
19.	Hose reducer	TPE	2

5. Assembly

Carry out the following steps and the corresponding illustrations for assembly (some parts are already pre-assembled).

Note: Before filling the tank with sand, the filter system should be in a fixed location. Otherwise, it may be difficult to move the unit.

1.) Mount the cover.

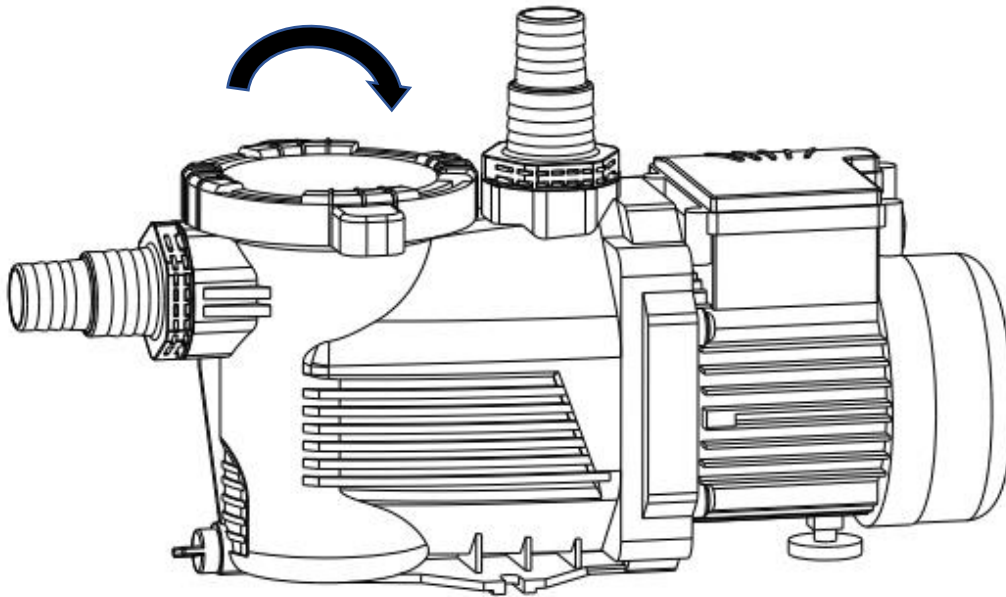

2.) Mount the pump to the base plate (7) with the four screws and nuts (8).

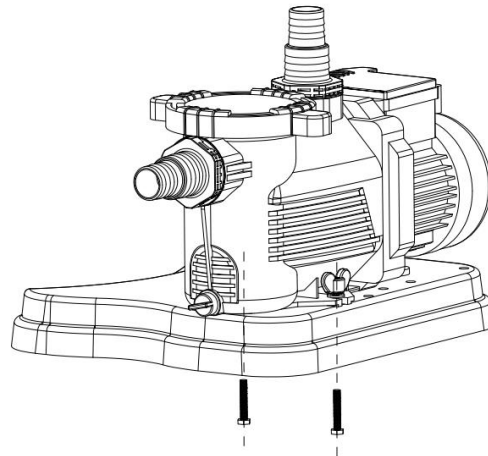
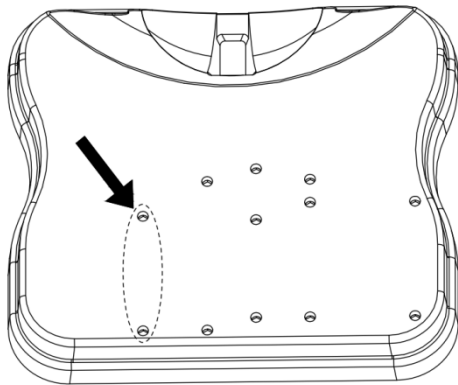

3.) Install the drain plug.

- a) Put the sealing on the thread of the plug. Put the valve from the inside through the hole of the tank.
- b) Put the Sealing on the outer side of the drain valve. Now screw the nut with the sealing against the outer wall of the tank.
- c) Make sure all parts are tightened. Put on the drain plug with its sealing inside.

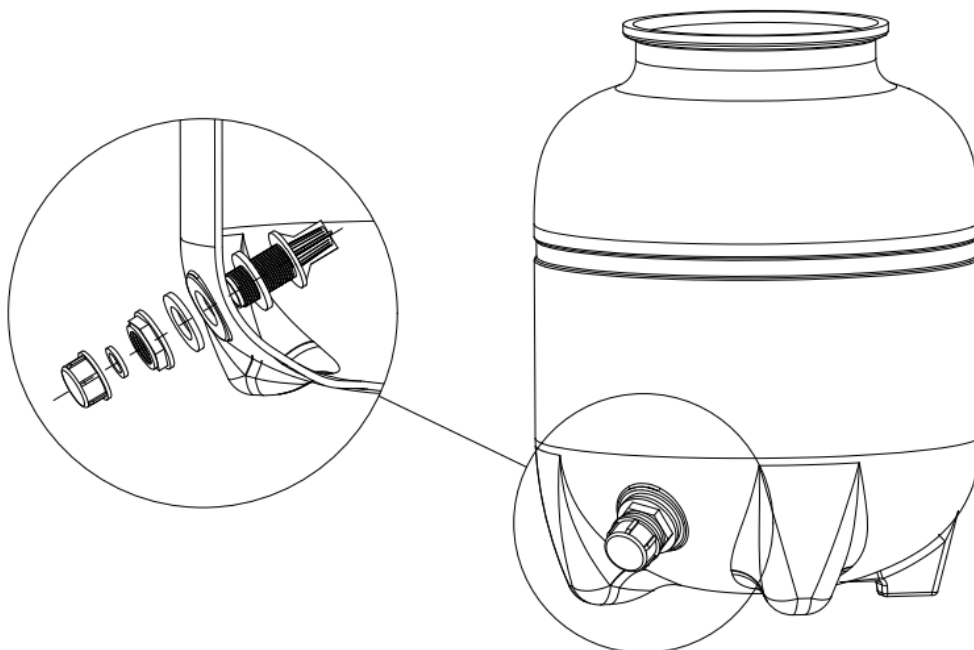

4.) Put the tank into the base and turn clockwise to lock it.

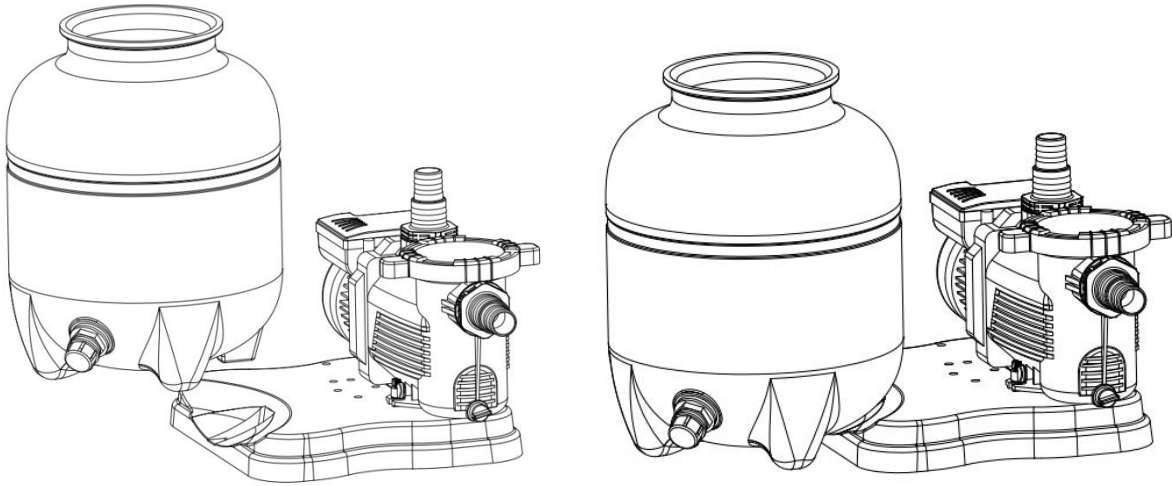

5.) Set the black filter pipe into the tank. Use the pattern (10) before filling in the sand. This avoids filter material inside the filter unit.

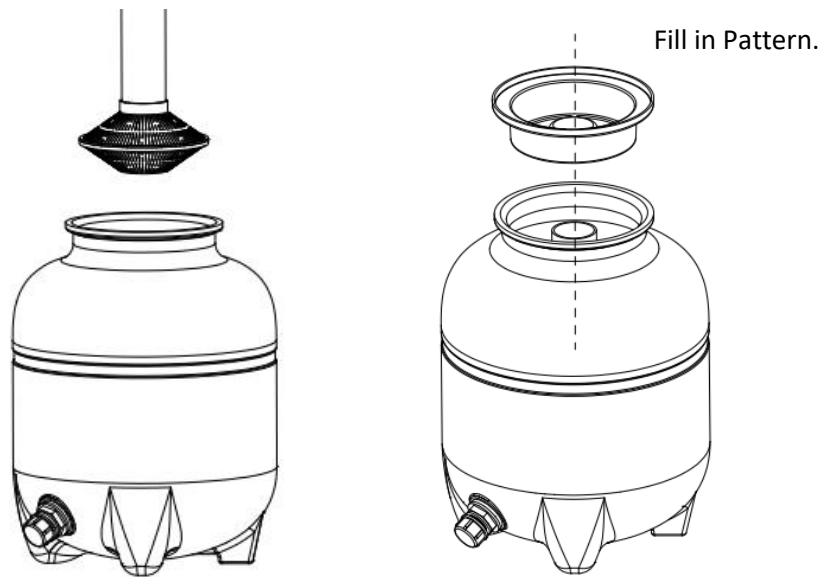

5.) Fill the tank with sand (max. 20kg). Take away the pattern after filling.



Caution: Avoid breathing in dust. Use a breathing mask approved for dust, sand and eye protection when filling the tank.

- a) Fill the tank with 1/3 water.
- b) Place the sand protection on the middle shaft of the distributor. This ensures that no sand gets into the distributor unit when filling the tank.
- c) Carefully fill the filter tank with the correct amount of #20 quartz sand (20 kg are required).

The sand should be filled at least halfway to the tank and at most to $\frac{3}{4}$. Overfilling will cause permanent damage to your filter system. Do not exceed the recommended quantity/weight of sand.

Important: Remove the sand protection after you have added sand. Keep it for future use.

7.) Assembly of 7-way-Valve to the tank.

Important: Make sure the filter pipe sits tight in the 7-way-Valve.

- a. Install the tank O-ring on the bottom of the 7-way valve.
- b. Note: Apply silicone grease or swimming pool lubricant (not supplied) around the seal before applying it to the valve. This will facilitate installation and provide a better seal.

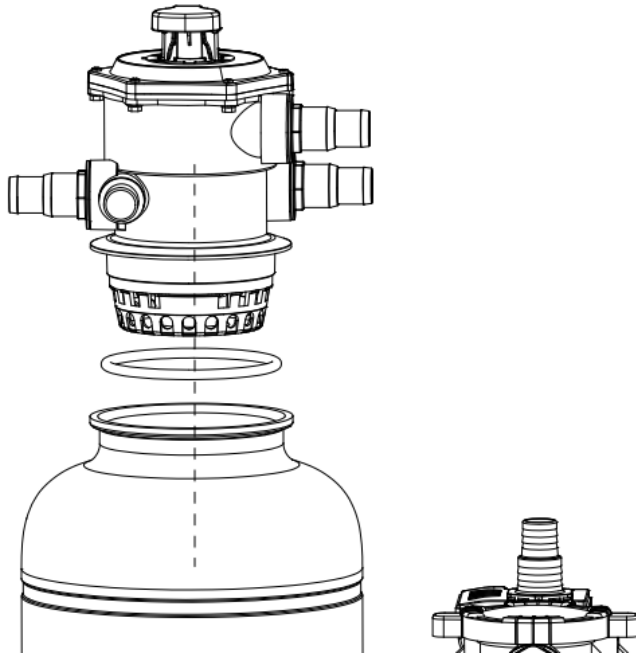

- b) Place the valve on the tank. Install the flange clamp around the tank and the valve flange. Tighten the valve just enough to allow it to rotate on the tank for final installation.
- c) Align the valve so that the pump connection points to the pump motor outlet.

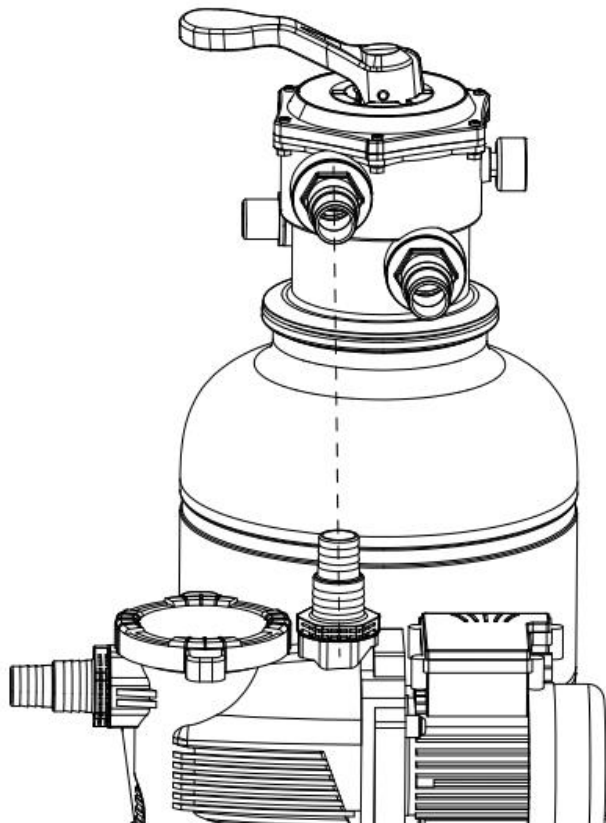

8.) Pump to 7-way-Valve

- a) Mount the connections with O-Ring to the exit of the pump and to the gate of the valve.

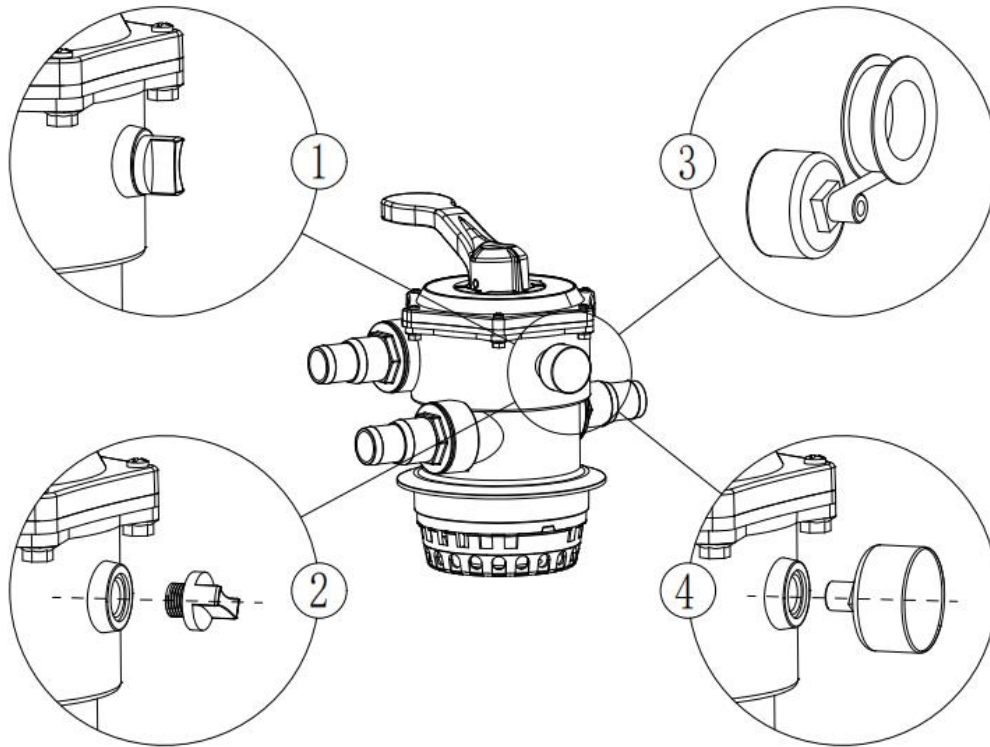

- b) Connect the pump with the valve ("Pump") by the hose (18) with reducer (19) and lock it with the clamps (11).

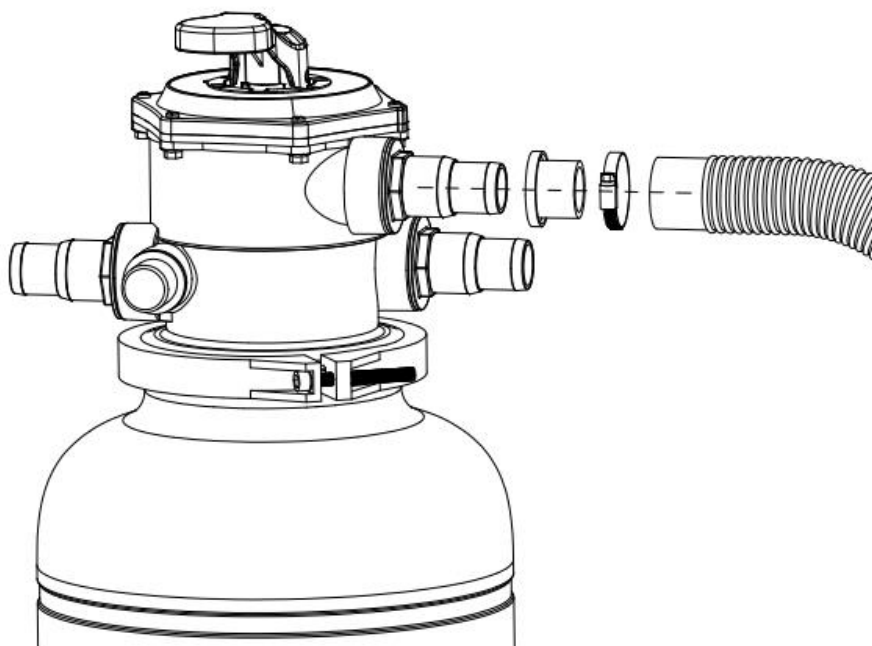

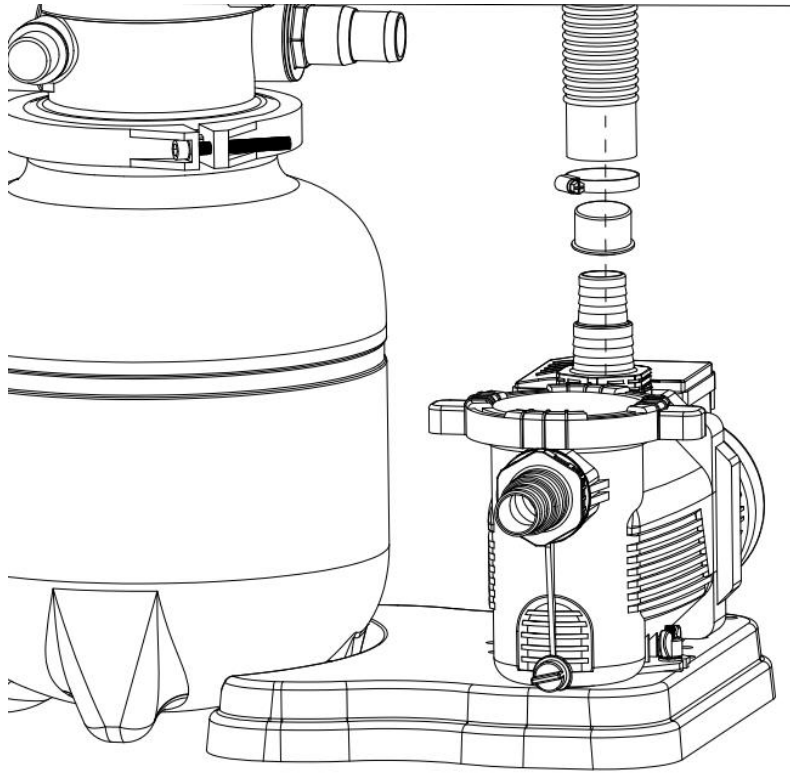

c) Tighten both hose clamps.

9.) Disassemble the small plug and screw in the pressure gauge with the sealing. **Do not overtighten!** Keep the small plug stored.

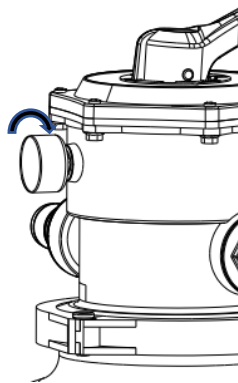

6. Filter Function

6.1 Connection of the Filter System

Caution: Before connecting hoses to the filter and pumping, make sure that no water can flow through the inlet or return hoses connected to the pool. Some pools have valves connected, others do not. If you do not have a shut-off valve, seal the ports with a removable plug to prevent water from entering the hoses.

Note: For pools with a diameter of 32mm or 38mm without threads, use the standard adapters.

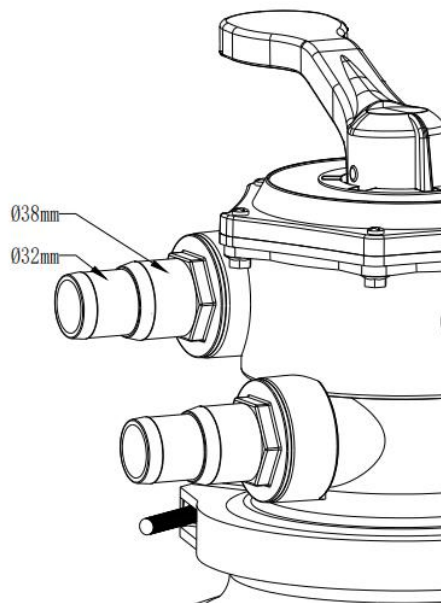

In these instructions it is assumed that the pool is already equipped with hoses attached to the water inlet and return connections of the pool.

- 1.) Connect a hose connection to the front of the filter housing and to the pool connection of the valve. Make sure the O-ring is in the adapter before attaching it.
- 2.) Attach the pool outlet hose to the hose connector of the filter housing. Refer to your pool manual for inlet/outlet hose information. Secure the hose to the adapter with a hose clamp or thread.
- 3.) Connect the pool return hose (pool inlet) to the pool connection adapter on the 7-way valve. Secure the hose to the adapter with a hose clamp or thread.

Note: Be careful not to attach the pool return hose to the waste/backwash connection.

- 4.) The installation of the filter pump is completed.

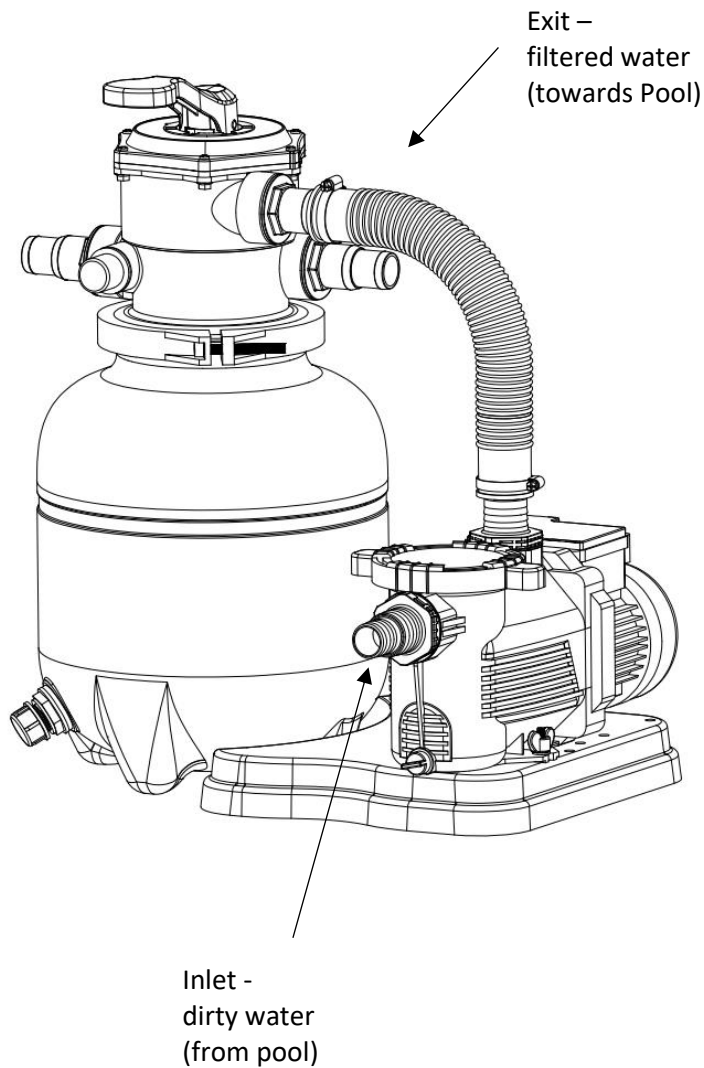

6.2 Warnings

- 1.) Make sure that the filter operates below the working pressure and use a pressure control valve if the system uses a booster pump.
- 2.) If the pump position is higher than the water level, the black water valve must be installed.
- 3.) If the pump position is lower than the water level, a shut-off valve must be installed. It could prevent the water from returning when persons perform the general inspection.
- 4.) Try not to bend the connection adapters and the hose connection. If the water flow is reduced, maximum effectiveness can be achieved.
- 5.) Make sure that no solvents are applied excessively to the fittings as they can get into the O-ring and cause sealing problems.
- 6.) Do not over-tighten screw connections or adapters.

7. Use

7.1 Before use

- 1.) Check that all connections have been made correctly and securely.
- 2.) Press the upper valve handle and turn it to the backwash position.
- 3.) Bleed and start the pump according to the pump instructions. NOTE: All suction and discharge valves must be open when starting the system. Failure to do so may result in serious personal injury. Make sure that the filter vessel is full. Fill the water before starting the pump, otherwise the pump will be damaged.
- 4.) Let the pump run for at least 2 minutes as soon as the water flow from the sewage pipe is steady. The first backwashing of the filter is recommended to remove any impurities caused by fine sand particles in the sand medium.
- 5.) Switch off the pump and set the valve to the Rinse position. Start the pump and let it run until the water in the sight glass is clear. This takes up to one minute. Switch off the pump, set the valve to FILTER and restart the pump. Your filter will now operate in normal filter mode and filter particles from the pool water.

7.2 Priming

The pump sucks in and refills the water of the filter tank and there is a sufficient supply from the suction point. If you lose water from the filter tank, you must top it up before starting.

- 1.) Remove the translucent cover and fill the filter tank with water.
 - 2.) Put the cover back on, make sure the O-ring is correctly seated and start the pump.
- After you have done this, wait a few minutes for the pump to deliver water.

Warning: A high suction lift or long suction lines require additional time for suction and can significantly affect the pump's performance. If the pump does not prime, repeat steps 1 and 2 above. Dry-running mechanical seals can be quickly damaged and may need to be replaced.

Make sure there is always sufficient water in the filter tank before you start. If you cannot prime the pump, please read the troubleshooting guide.

Make sure that all suction and discharge valves are open before starting the pump, otherwise the pump will be damaged.

7.3 During use

- 1.) Write down the initial pressure gauge value when the filter is clean (it varies depending on the pump and general pool piping system). As the filter removes dirt and impurities from the pool water, accumulation in the filter will cause the pressure to increase and the flow to decrease. If the pressure gauge is 8-10 (PSI) (0.55-0.69 BAR) above the initial pressure you noted for "Clean", it is time to clean the filter.
- 2.) Important: To avoid unnecessary stress on the piping system and valves, always turn off the pump before changing the position of the filter control valve.
- 3.) Clean the pump strainer and skimmer baskets regularly to prevent damage to the pump and filter and to ensure proper operation of the system.

7.4 Functions

Filter: Set the valve to FILTER for normal filtering. Also use for regular vacuuming.

Backwash: For cleaning the filter. When the filter pressure gauge rises 9-10 PSI (0.55-0.69 BAR) above start-up (clean pressure).

Rinse: After backwashing, set the valve to RINSE with the pump turned off. Start the pump and let it run for about 1 minute. This will ensure that all the dirty water is flushed out of the filter and does not flow back into the pool. Stop the pump, set the valve to Filter and start the pump for normal filtration.

Circulation: Circulate water after chemical treatment.

Closed: Stop the flowing, Cleaning the hair and lint strainer

Waste: For vacuuming pools with large amounts of debris or after algae treatment.

Winter: The valve is open so that it does not stress the seal.

Important: Turn off the pump when changing the position of the filter control valve.

8. Troubleshooting

Problem	Cause	Solution
Low pressure	Dirty sieve basket	Clean the sieve basket
Air in pump	Bad sealing on pump's suction side	Tighten hose clamps and connections
Water flows into the drain pipe	Dirt at 4-way-valve sealing	Clean this sealing.
Leaking Filter	<ul style="list-style-type: none"> - Defect sealing - Loose hose clamp 	<ul style="list-style-type: none"> - Check the sealing and replace it if necessary. - Tighten the clamps. Do not overtighten. Replace if necessary.
Pump not running	<ul style="list-style-type: none"> - Plug not plugged - Fuse triggered - Motor defect 	<ul style="list-style-type: none"> - Check socket and plug - Check Fuse. If fuse triggers again directly, there's a defect at the pump - Replace the pump
Sand in Pool	<ul style="list-style-type: none"> - When sand was replaced, the smallest parts will flush in - Sand in central valve (due to flushing) - Sieve is damaged 	<ul style="list-style-type: none"> - Flush if the water is dirty - Flush for 30sec into drainpipe - Replace the sieve
Air in system	Low water level or the system was opened for maintenance	With the pump running, loosen the pressure gauge or pressure gauge plug, but do not remove it to release air. Then retighten the gauge or plug.

9. Maintenance

9.1 Cleaning

The screen basket in the filter tank should be checked and cleaned at regular intervals.

- 1.) Remove the lid and lift out the basket.
- 2.) Remove dirt and spray with water if necessary.
- 3.) Check the cover gasket, grease it with silicone grease only if necessary. If it is damaged, please replace it.
- 4.) Replace the strainer.
- 5.) Bleed the filter tank again.
- 6.) Locate the O-ring correctly.
- 7.) Put the cover back on (pull hand tight).
- 8.) Switch on the pump.

In climates where the pump may be exposed to frost, make sure that the pump is protected from damage. It is recommended to store the pump in a dry place when not in use in winter. Do not replace the drain plug. Keep it in a safe place when not in use.

When you restart the pump, make sure that all seals and O-rings are operational. Grease them if necessary and replace them if you are not sure. Check that the motor shaft moves freely before reactivating it.

9.2 Warnings

- 1.) When connecting electrical cables to the motor of the pump, make sure that they are correctly laid in the connection box. Make sure that no cable remains in the box when closing it. Make sure that the grounding cable is connected correctly. Follow the wiring diagram supplied with the pump when connecting the motor.
- 2.) Take special care that no water under voltage gets into the motor or into the electrical parts.
- 3.) In case of improper use, adjustments and additional technical rules may be necessary.
- 4.) Before starting the pump, make sure that the electrical protection devices of the motor are calibrated and that the protection devices against electrical and mechanical contacts are correctly positioned and fitted.
- 5.) It is recommended to follow the steps below before handling the pump in any way.
 - a) Switch off the power to the pump.
 - b) Lock the starting devices
 - c) Make sure that the electric circuits, including auxiliary equipment and auxiliary circuits, are de-energized.
 - d) Wait until the motor has come to a complete stop.

The list above should be considered as a guide and is not binding for safety reasons. Special safety rules may exist in certain regulations.

9.3 To be checked regularly

- 1.) Correct fastening of the mechanical parts and the support screws of the pump.
- 2.) Correct position, fastening and condition of the supply cables and insulating parts.
- 3.) The temperature of the motor. If the value is too high, stop immediately and have it repaired.

4.) The vibration of the pump. If the value is too high, stop immediately and have it repaired.

Warning: All electrical work may only be carried out by a qualified electrician. Under no circumstances attempt to repair the electrical components of pumps unless you are qualified to do so.

10. Environmentally friendly disposal

Warning Danger of suffocation! Packaging material is dangerous for children. Never let children play with packaging material.

10.1 Disposal and packaging

- The packaging of your unit consists of materials that are necessary to guarantee effective protection during transport. These materials are fully recyclable and therefore reduce the environmental impact. Dispose of the packaging in a bin for recyclable materials.

10.2 Disposal of old equipment

- Old appliances must be disposed of in accordance with the guidelines and regulations of the local waste disposal authority. Check with your local administration for the address of the nearest recycling centre and deliver your appliance there.



The symbol of the crossed-out dustbin on a Waste electrical or electronic equipment indicates that it must not be disposed of with household waste at the end of its life. Collection points for waste electrical and electronic equipment are available free of charge in your area. You can obtain the addresses from your city or local government. You can find out about other return options created by us on our website www.arebos.de.

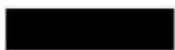

The separate collection of Waste electrical or electronic equipment is intended to enable the reuse, recycling or other forms of recovery of Waste electrical or electronic equipment and to avoid the negative consequences of disposal on the environment and human health.

Our customer service number: Tel. +49 931 90 80 3000

E-Mail: info@arebos.de

Office address: Canbolat Vertriebs GmbH • Gneisenaustraße 10-11 • 97074 Würzburg

Return address can be found in the imprint: <https://www.arebos.de/impressum/>

EU Declaration of Conformity

We, the

Canbolat Vertriebs GmbH, Gneisenaustraße 10-11, 97074 Würzburg, Germany,

hereby declare that the equipment described below, by virtue of its design and construction and in the versions placed on the market by us, complies with the relevant essential health and safety requirements of the EU directives.

Name of the product: AREBOS Sand Filter System

Model Nr.: AR-HE-SAS350FS, AR-HE-SAB350FS, AR-HE-SAG350FS

Art. Nr.: 4252023126465 (blue); 4252023126472 (grey); 4252023126489 (black)

Should the appliance be modified without our consent, this declaration of conformity will lose its validity.

Tested acc. to:

EN IEC 55014 - 1 : 2021

EN IEC 55014 - 2 : 2021

EN 61000 - 3 - 3 : 2013+A1

EN IEC 61000 - 3 - 2 : 2019+A1

EN 60335-1:2012+A11+A13+A1+A14+A2+A15

EN60335 – 2 – 41 : 2021+A11

EN 62233 : 2008

AfPS GS 2019 : 01 PAK

EC Council Directive 2006/42/EC

Machinery Directive

EC Council Directive 2014/30/EU

EN IEC 60335-2-41:2021+A11

EK1 527-12 Rev. 2

Date/Signature Manufacturer/Place:

Würzburg, December 18, 2024

Signature:

Dipl.-Inform. (Univ.) Korhan Canbolat, Managing Director

Representative of these instructions for use/technical data:

Dipl.-Inform. (Univ.) Korhan Canbolat, Managing Director

Office address:

Canbolat Vertriebs GmbH

Gneisenaustraße 10-11

D-97074 Würzburg

Return address can be found in the imprint: <https://www.arebos.de/impressum/>

VAT identification number: DE 263752326

Court of the Commercial Register is Würzburg, HRB 10082

WEEE Reg.-No. DE 61617071